

ScholarWorks@GSU

The ESG Behaviors of Multinational Enterprises: An Exploration of Emerging and Developed Market Norms

Authors	Anderson, Julie A
Citation	Anderson, Julie A. "The ESG Behaviors of Multinational Enterprises: An Exploration of Emerging and Developed Market Norms." 2021. Dissertation, Georgia State University https://doi.org/10.57709/22831181
DOI	https://doi.org/10.57709/22831181
Download date	2026-05-08 12:18:06
Link to Item	https://hdl.handle.net/20.500.14694/2454

PERMISSION TO BORROW

In presenting this dissertation as a partial fulfillment of the requirements for an advanced degree from Georgia State University, I agree that the Library of the University shall make it available for inspection and circulation in accordance with its regulations governing materials of this type. I agree that permission to quote from, copy from, or publish this dissertation may be granted by the author or, in her absence, the professor under whose direction it was written or, in his absence, by the Dean of the Robinson College of Business. Such quoting, copying, or publishing must be solely for scholarly purposes and must not involve potential financial gain. It is understood that any copying from or publication of this dissertation that involves potential gain will not be allowed without written permission of the author.

Dr. Julie A. Salsbery

NOTICE TO BORROWERS

All dissertations deposited in the Georgia State University Library must be used only in accordance with the stipulations prescribed by the author in the preceding statement.

The author of this dissertation is:

Dr. Julie A. Salsbery
J. Mack Robinson College of Business
Georgia State University
Atlanta, GA 30302-4015

The director of this dissertation is:

Dr. Vikas Agarwal
J. Mack Robinson College of Business
Georgia State University
Atlanta, GA 30302-4015

The ESG Behaviors of Multinational Enterprises: An Exploration of Emerging and Developed
Market Norms

by

Julie A. Salsbery

A Dissertation Submitted in Partial Fulfillment of the Requirements for the Degree

Of

Doctorate in Business Administration

In the Robinson College of Business

Of

Georgia State University

GEORGIA STATE UNIVERSITY

ROBINSON COLLEGE OF BUSINESS

2021

Copyright by
Julie A. Salsbery
2021

ACCEPTANCE

This dissertation was prepared under the direction of the *JULIE ANN SALSBERY* Dissertation Committee. It has been approved and accepted by all members of that committee, and it has been accepted in partial fulfillment of the requirements for the degree of Doctor of Philosophy in Business Administration in the J. Mack Robinson College of Business of Georgia State University.

Richard Phillips, Dean

DISSERTATION COMMITTEE

Dr. Vikas Agarwal (Chair)

Dr. Oğuzhan Karakaş

Dr. Scott Murray

ACKNOWLEDGEMENTS

I would like to express my sincere gratitude to my esteemed dissertation chair, Dr. Vikas Agarwal, for his thoughtful engagement and invaluable advice. I would also like to thank my committee members, Dr. Oğuzhan Karakaş and Dr. Scott Murray, for their genuine interest in my research topic and critical feedback. I must also recognize Justin Lee for his assistance with the preliminary coding and Dr. Heiko Bailer at RepRisk for providing both data and guidance.

I would like to especially thank the individuals in my cohort for their friendship, support, and advice. I am forever grateful for the lifelong bonds we have created on this often challenging but always rewarding journey. We lifted each other during the lows, laughed riotously during the highs, and always endeavored to preserve our collective sanity.

Finally, I would like to express my deepest appreciation to my friends and family. To my close personal friends and former colleagues who are also dear friends, thank you for indulging my need for intellectual engagement, listening to my near constant flow of ideas, and for always sharing your thoughtful feedback.

Most importantly, I am eternally grateful for my mother Jacquelyn and my husband Eric. Their love, belief in my abilities, and unwavering encouragement have and continue to provide a strong foundation for my life and education. Lastly, this dissertation is dedicated to my children, MacLean and Tatum. To be their mother is the greatest joy of my life and I am thankful for their understanding and support during the many hours I have selfishly dedicated to my own education. Having instilled in them a thirst for global knowledge and engagement is my life's greatest achievement and I hope this degree further inspires them.

Table of Contents

ACKNOWLEDGEMENTS	iv
LIST OF FIGURES	vii
I Introduction	1
II Literature Review & Contributions.....	5
II.1 Measurement of ESG Quality	5
II.2 Factors influencing ESG quality.....	7
II.3 Global Context	8
III Hypotheses Development	10
III.1 Background.....	10
III.2 Proposed Behavior Types	11
III.3 Sources of Difference in CSI Norms.....	15
III.4 Changes in CSI behavior Over Time	17
IV Data Sources & Variable Construction	19
IV.1 Data Sources	19
a. Unit of Analysis	21
b. Variable Construction	22
IV.2 Background/Summary Statistics	23
V Findings	24
V.1 CSI Behavior Types – Adopter or Exporter.....	24
V.2 Sources of Difference in CSI Scores at Home and Abroad.....	29
V.3 Changes in CSI Over Time	32
c. Robustness Checks.....	37

VI Discussion 41

VI.1 Contribution 41

VI.2 Limitations & Future Research 43

VII Conclusion 46

Appendices..... 47

Appendix A: Tables 47

VITA 72

LIST OF FIGURES

Figure 1: Model of CSI Norms	11
Figure 2: Models of CSI Behavior Types.....	13
Figure 3: 2x2 Matrix of Behavior Norms	22
Figure 4: Mean CSI Score	24
Figure 5: 2x2 Matrix of Subcomponent Norm Scores.....	25
Figure 6: Schematic of CSI Behavior Types.....	26
Figure 7: Schematic of Subcomponent Behavior Types.....	27
Figure 8: Subcomponent Scores Over Time.....	35
Figure 9: CSI Norms by Market Incident Location and Market Headquarters Over Time	36
Figure 10: Mean vs. Median Subcomponent Scores.....	38
Figure 11: Subcomponent Scores for Full Sample vs. Sample without US and China	40

ABSTRACT

The ESG Behaviors of Multinational Enterprises: An Exploration of Emerging and Developed
Market Norms

by

Julie A. Salsbery

April 2021

Chair: Vikas Agarwal

Major Academic Unit: Finance

This paper examines how, when, and where environmental, social, and governance (ESG) behavior varies globally. I build on existing research that proposes country-of-origin constructs, such as regulatory and cultural foundations, influence ESG behavior of firms. Specifically, I propose that perceived differences in ESG standards for developed and emerging markets incentivize multinational enterprises (MNEs) to exhibit different levels of Corporate Social Irresponsibility (CSI) when operating abroad versus at home. My findings show that developed market-headquartered MNEs behave more irresponsibly in emerging markets than they do at home, while emerging market MNEs behave better when operating in developed markets. Importantly, the abroad-versus-home differences in the ESG behavior of MNEs appears to be driven more by governance than social or environmental factors. These findings contribute to the understanding of how presence in multiple markets shapes the ESG behavior of MNEs. This research contributes to practice by illuminating market-based norms that can act as benchmarks for ESG-focused investors and help guide shareholder engagement activities. Importantly, it offers nuanced insights for global policymakers as they seek to achieve better ESG outcomes for society.

INDEX WORDS: ESG, CSR, Multinational Enterprise, Emerging Markets

I INTRODUCTION

“The business of business is business.” Milton Friedman, 1970

Global headlines are rife with examples of firms behaving badly. From widespread corruption in Brazil and industrial chemical leaks in India to the use of child labor in China, the pursuit of profits can lead to the exploitation of people and harm to society and its environment. However, these incidents are not exclusively a problem in emerging market (EM) countries as the previous examples might suggest. Gender inequality and data breaches are a growing source of concern in the developed markets (DM), and corruption and fraud are enduring global problems. Fortunately, because media reports of irresponsible corporate actions have the potential to impact financial asset prices, investors are increasingly interested in examining how the Corporate Social Responsibility (CSR) practices and Environmental, Social, and Governance (ESG) behaviors of the firms they invest in may impact outcomes for society. Public interest, both anecdotally and through rising investment inflows, is further incentivizing investors to examine ESG behaviors. According to the biennial Global Sustainable Investment Alliance¹ report, asset flows into investment strategies that consider ESG factors grew to \$30.7 trillion in 2018, a 34% increase from 2016.

While ESG-related investing is clearly one of the most important and fastest growing trends in asset management, ESG-related regulations and metrics by which firms are judged remain ill-defined and lacking in global consistency. To fill the current void, there are a number of third-party rating agencies that provide ESG ratings similar to the credit ratings provided by firms such as Moody’s and Standard & Poor’s. Unfortunately, these ratings are often based

¹ <http://www.gsi-alliance.org/trends-report-2018/>. To put this figure in a context, mutual fund assets globally at the end of 2018 were \$46.7 trillion per the Investment Company Institute (<https://ici.org/research/stats/worldwide>).

upon a firm's CSR report, statements on its website, or how management answers ESG-related questions when engaged on such topics. As a result, these ratings may suffer from self-reporting bias, or may more accurately reflect what a firm *claims* to do rather than its *actual* behavior. This research utilizes a unique database from RepRisk that provides firm-level raw scores based on actual ESG-related violations as reported in the media or by non-government organizations (NGOs). In this way, it measures the Corporate Social Irresponsibility (CSI) of firms (Fiaschi et al., 2017; Strike et al., 2006). This research aggregates these firm-level scores to analyze patterns of CSI across developed and emerging markets.

Aligning with investors' most pressing concern, literature from the field of finance is predominantly focused on how ESG factors affect the financial performance of firms. While there is evidence on both sides, the majority of research demonstrates a positive relation between ESG quality and financial performance (e.g., see meta-analysis by Friede et al., 2015). From the practitioners' point of view, the knowledge that ESG factors may influence financial performance heightens the need to understand how to judge a firm's ESG quality relative to its peers, as well as how ESG trends are evolving in global markets. A smaller but growing and multidisciplinary body of research (spanning international business, ethics, strategic management, and finance) examines factors that may influence the ESG quality of firms globally. A portion of this body of research looks at how and why multinational enterprise (MNE) ESG quality changes when operating abroad. Because MNEs are responsible for an estimated one-third of global output, half of global exports, and one-fourth of global employment, they are in a powerful position to significantly impact global ESG outcomes.² This

² Multinational enterprises in the global economy, heavily debated but hardly measured. OECD, May 2018. <https://www.oecd.org/industry/ind/MNEs-in-the-global-economy-policy-note.pdf>

paper expands upon the subject by examining the CSI of MNEs from both emerging and developed markets when operating at home and abroad. Specifically, I ask, “Do multinational enterprises export or adopt Corporate Social Irresponsibility?”

I begin my analysis by proposing a model of behavior that explains the relation between a MNE’s CSI behavior at home versus abroad, based on the location of its headquarters. The model proposes that MNEs will either choose to ‘export’ the CSI norms of their home market (headquarters) or ‘adopt’ the CSI norms of their host market (location of foreign operations). For example, because DM-headquartered firms often expand into EM to achieve a competitive advantage through lower supply chain costs, one might expect DM-headquartered MNEs to behave *worse* when operating in emerging markets than they do at home in the developed markets. Such a difference in CSI behavior would signal an ‘adoption’ of the weaker ESG regulatory environment (poorer working conditions, lower environmental thresholds, etc.) in EM. Next, I analyze the degree to which CSI subcomponent behaviors (environmental, social, and governance-specific actions) contribute to the difference in MNE behavior at home and abroad. Lastly, I examine how CSI has changed over time for EM- and DM- headquartered firms when operating at home and abroad.

Importantly, this research contributes to practice in two ways. First, by identifying the CSI norms in emerging and developed markets and for MNEs when operating both at home and abroad, I provide a valuable and relative context for investors when analyzing a particular firm’s ESG quality. Second, distinguishing the patterns of CSI subcomponent behavior (environmental, social, and governance) between EM- and DM-headquartered firms will facilitate more focused stakeholder engagement. Further, a better understanding how CSI is

changing over time will enable policymakers and activists to better focus their agendas to influence future outcomes for society.

II LITERATURE REVIEW & CONTRIBUTIONS

A rapidly growing proportion of investors believe ESG factors will contribute to future asset returns. In concert with this practitioner-based trend, there is an extensive and rich body of academic literature examining the relation between ESG factors and financial performance. Though inconclusive and difficult to generalize, a majority of the research shows a positive relation between ESG quality and performance (Friede et al., 2015). Outside of the financial performance link to ESG, there is a smaller, more recent body of multidisciplinary research that examines the factors that influence a firm's ESG quality. This research aims to contribute to three key components within this body of knowledge.

II.1 Measurement of ESG Quality

The first contribution relates to the variable being used to examine the ESG-quality construct, which is often referred to as Corporate Social Performance (CSP) (Cai et al., 2016; Ioannou & Serafeim, 2012; Zygliopoulos et al., 2016). The vast majority of research uses either a firm's CSR report or third-party ESG ratings to quantify a firm's CSP. There are four notable drawbacks in using these sources as a proxy for the CSP construct. First, CSR reports typically contain philanthropic initiatives and a description of the firm's commitments to social and environmental issues, rather than a robust or quantitative assessment of a firm's ESG-related actions. While third-party ESG ratings utilize some popularly agreed upon and consistent ESG metrics, they also may rely heavily on statements of ESG-related intentions made in a firm's CSR report or on its website, as well as through direct conversation with firm management. As such, these sources may be subject to self-reporting bias and as a result may reflect a firm's *claim* or desired level of ESG quality more so than its *actual* ESG-related behavior or impact (Marano et al., 2017). A second drawback occurs when third-party ratings

utilize both positive and negative ESG information. Because negative ESG-related actions have shown to have more impact on financial performance (Capelle-Blancard & Petit, 2019; Krüger, 2015) and negative ESG developments are more important in terms of risk for investors (Dorfleitner et al., 2015), adding positive and negative ESG factors together may create an offsetting effect that obscures the value of the negative event or factor (Strike et al., 2006).

A third drawback for ESG ratings is that the lack of globally-accepted, industry-specific reporting metrics or guidelines causes third-party ESG ratings to be inconsistent. For example, an examination of three popular ESG rating providers (Asset4/ThomsonReuters, KLD/MSCI, and Bloomberg) found a lack of convergence in how ESG concepts are measured as well as the distribution of the ratings (Dorfleitner et al., 2015). While practitioners appropriately utilize third-party ESG ratings as an independent view or opinion of the ESG quality of a firm rather than a factual assessment of its quality, the use of third-party ratings in academic research may introduce uncertainty about construct validity. The fourth drawback is timeliness. Because ESG ratings often rely on underlying data that may be static or persistent and the ratings themselves are often updated annually, they may be more reflective of past conditions and/or be inefficient at capturing timely changes in behavior (Chatterji et al., 2016; Dimson et al., 2015; Dorfleitner et al., 2015).

Lastly, the majority of research focuses exclusively on the environmental and social aspects of the ESG construct, and purposely excludes the governance aspect (Amor-Esteban et al., 2018; Dyck et al., 2019; Ioannou & Serafeim, 2012; Marano et al., 2017), while others focus solely on social (Fiaschi et al., 2017) or governance factors (Filatotchev et al., 2019). This paper expands on this body of research by (1) using actual ESG-related behaviors rather than a firm's claims about its behavior, (2) focusing on the negative or irresponsible ESG behaviors that

matter most to investors, and (3) examining a fuller range of ESG constructs (environmental, social, governance, and cross-cutting, also referred to herein as E, S, G, and CC; see IV.1. Data Sources for more details).

II.2 Factors influencing ESG quality

The second contribution relates to the factors that influence the level of ESG quality. The two most often researched sources of influence are a firm's country-of-origin (COO, or where a firm is headquartered) and the firm's strategic business motivation for embarking on ESG-related commitments or initiatives. Within COO-oriented research, independent variables are typically nation-level constructs such as the degree of freedoms (i.e., media and political), the legal framework (common law or civil law), and World Governance Indicators such as corruption, rule of law, political stability, etc., (Amor-Esteban et al., 2018; Fiaschi et al., 2017; Ioannou & Serafeim, 2012; Marano et al., 2017; Tashman et al., 2019); though more abstract concepts such as harmony, culture, and liberty have also been examined (Cai et al., 2016). From the research on strategic business motivations as the main driver of ESG quality, stakeholder pressure and institutional ownership are shown to contribute (Dimson et al., 2015; Dyck et al., 2019; Filatotchev & Stahl, 2015; Surroca et al., 2013), though reputation-building efforts is also frequently theorized as a contributor (Filatotchev & Stahl, 2015; Gugler & Shi, 2009). This paper advances and combines these two sources of influence. First, rather than use nation-level constructs, which can be hard to measure and are often persistent, this paper utilizes mean CSI scores as representation of the 'norm' – the typical or standard level of CSI for the group/region being examined (EM and DM in this case). Understanding market norms is well-aligned with the industry standard of looking at developed versus emerging market credit quality and the desire to have a benchmark from which to compare individual asset scores. Second, the COO

and strategic business motivations are considered in both hypotheses development and the explanation of findings.

II.3 Global Context

The third contribution relates to the global context of the ESG behavior being studied. When examining MNEs, there are two dimensions that may be considered – where the firm is headquartered and where the CSI takes place. Most often, the extant literature is focused on ESG quality as it relates to either DM-headquartered (Amor-Esteban et al., 2018; Ioannou & Serafeim, 2012; Surroca et al., 2013) or EM-headquartered MNEs (Fiaschi et al., 2017; Filatotchev & Stahl, 2015; Marano et al., 2017; Tashman et al., 2019) in isolation. When location of CSI is considered, it is often solely from the perspective of when the MNE operates abroad. This paper presents a more holistic approach by examining both DM- and EM-headquartered MNEs and comparing the CSI norms of MNEs to the CSI norms at home and abroad.

In summary, while there is growing evidence that ESG factors can contribute to financial performance, and well-articulated reasons for why MNEs undertake and reveal their ESG commitments, there is little understanding of who is doing what and where. This paper expands on the existing body of knowledge first by using publicly reported CSI instead of a firm's self-reported claims to quantify ESG impact, second by aggregating CSI as an indication of a market's norm rather than relying on nation-level constructs to gauge market-based differences, and third, provides a more holistic view by examining CSI patterns at home and abroad for MNEs headquartered in both developed and emerging markets. By filling these gaps, this research contributes to sustainable finance practice by focusing on the negative or irresponsible behavior that drives financial performance and analyzes behavior patterns through the EM-DM

market lens investors use. A better understanding of the CSI norms in EM and DM, as well as the sources of difference in MNE norms when operating at home and abroad, will help investors analyze and compare the relative ESG quality of their investments.

III HYPOTHESES DEVELOPMENT

III.1 Background

In asset management, EM firms are typically considered to be riskier than DM firms and much of that assessment has to do with a perceived poorer quality of governance, often related to their COO. The COO-based perception of less regulation and fewer resources in EM appears to be translating into an opinion that EM countries also have less rigor around ESG issues. For example, it is generally accepted that there is a positive relationship between credit quality and ESG quality for sovereign bonds (i.e., Allianz, MSCI³) and this relationship appears to be mimicked in ESG ratings which are not equally distributed across EM and DM. Specifically, a report by MSCI states that “More than 80% of the constituents of the MSCI World Index [DM] received an ESG Rating between BB and AA. Conversely, more than 80% of the constituents of the MSCI Emerging Markets Index and the MSCI AC Asia ex Japan Index were rated at or below BBB.”⁴ This DM-EM assessment may be appropriate for domestic-only firms, but because MNEs cross national boundaries, it raises the question as to the appropriateness of a generalization to all firms. In other words, if ESG behavior in EM is poorer than in DM, further investigation is needed to determine if domestic or foreign firms are responsible for the difference. Leveraging institutional theory, specifically regarding the homogeneity of business practices that develops within organizational groups over time (DiMaggio & Powell, 1983), this research examines the differences in CSI in emerging and developed markets from two different

³ <https://es.allianzgi.com/-/media/allianzgi/eu/makler-spain-new/documents/sri-seminar/esg-in-sovereign-bonds.pdf>

⁴ Dispersion of MSCI ESG Ratings as of Sept. 30, 2019. <https://www.msci.com/www/blog-posts/integrating-esg-in-emerging/01747190687>

dimensions: (1) the market where the CSI takes place, and (2) the market of headquarters for the firm that perpetrates the CSI.

III.2 Proposed Behavior Types

This research begins with the premise that a market-based aggregation of firm-level CSI scores can be regarded as the regulatory or societal ‘norm’ of the CSI of that market. For example, the average of all DM-headquartered firm-level CSI scores from operations in DM countries at a specific time can be used as a proxy for the ‘DM CSI norm’ at that time. The same can be said for the aggregation of EM-headquartered firm-level CSI scores in EM countries for the same time period. Given this, one can compare the CSI norms of MNEs when operating abroad relative to the ‘home’ (headquartered) market norm and the ‘host’ (foreign location of operations) market norm. A diagram of these norms and the behavioral relationships is shown in Figure 1 below.

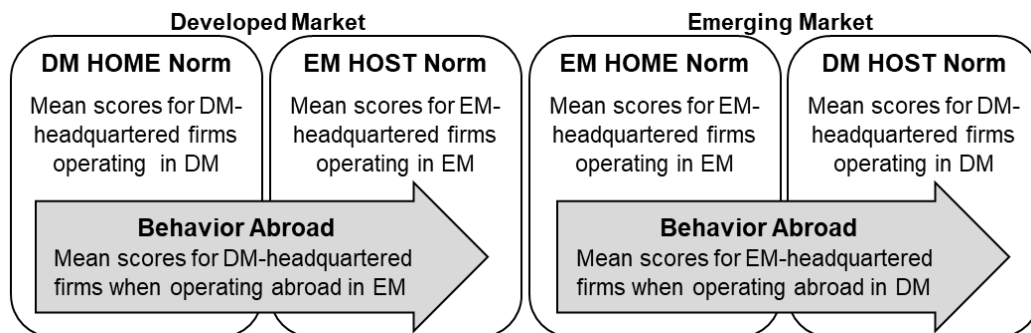

Figure 1: Model of CSI Norms

This paper proposes two CSI behavior types for MNEs when operating abroad: Exporter and Adopter. A CSI Exporter would score similarly abroad as it does at home, while the Adopter would have an abroad score that is more similar to the host’s norm. For example, let us assume that the DM CSI home norm is 40 and the EM CSI home norm is 80. If the average of DM-headquartered MNE scores when operating abroad in EM is similar to the DM CSI home norm,

they would be considered ‘exporters’ of the relatively better DM CSI home norm (note that a lower value of CSI is better because it corresponds to lesser or fewer ESG-related violations). Alternatively, if the average of DM-headquartered MNE scores is closer to the EM CSI home norm when operating abroad, they would be considered ‘adopters’ of the poorer EM host norm (note that the EM CSI home norm is the EM ‘host’ norm when compared to a DM MNE operating in EM). A diagram of the two behavior types is shown below for both DM- and EM-headquartered MNEs.⁵

⁵ See Section IV.2 Unit of Analysis for a description of DM and EM. There are 57 sovereign territories that are not classified as EM or DM and are excluded from this research: Åland Islands, American Samoa, Andorra, Anguilla, Antarctica, Bermuda, Bonaire, Sint Eustatius and Saba, Bouvet Island, British Indian Ocean Territory, Cayman Islands, Christmas Island, Cocos (Keeling) Islands, Cook Islands, Cuba, Curaçao, Falkland Islands, Faroe Islands, French Guiana, French Polynesia, French Southern Territories, Gibraltar, Greenland, Guadeloupe, Guam, Guernsey, Heard Island and McDonald Islands, Holy See, Isle of Man, Jersey, Democratic People's Republic of Korea, Liechtenstein, Martinique, Mayotte, Monaco, Montserrat, New Caledonia, Niue, Norfolk Island, Northern Mariana Islands, Palestine, State of Pitcairn, Qatar, Republic of North Macedonia, Réunion, Saint Barthélemy, Saint Helena, Saint Martin (French part), Saint Pierre and Miquelon, Sint Maarten (Dutch part), South Georgia/South Sandwich Islands, Svalbard and Jan Mayen, Tokelau, Turks and Caicos Islands, Virgin Islands (British), Virgin Islands (U.S.), Wallis and Futuna, and Western Sahara.

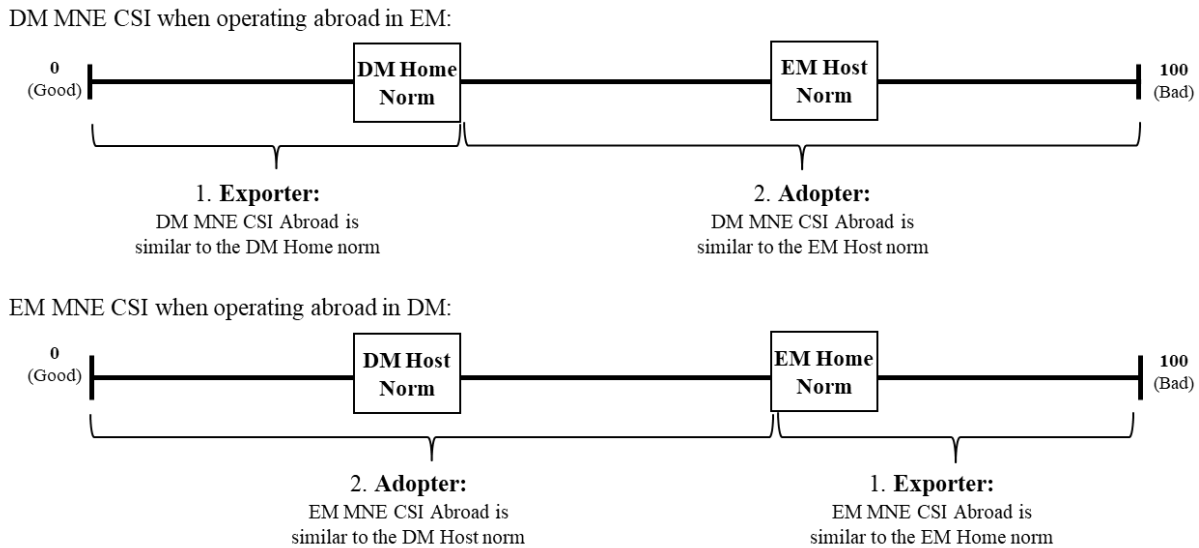

Figure 2: Models of CSI Behavior Types

In the above model, DM MNEs that choose to adhere to a higher standard of ESG-related conduct when operating in EM, such as the global labor standards often expressed in international treaties, would be exhibiting ‘Exporter’ behavior. DM MNEs may choose the Exporter behavior type for a variety of reasons including reputation building, meeting global stakeholders’ demands, increasing local community relations, or due to fear of market or consumer backlash (Dimson et al., 2015; Gugler & Shi, 2009). Alternatively, DM-headquartered firms that expand into emerging market locations to take advantage of more lenient environmental or social regulatory requirements (i.e., ‘pollution havens’) would be exhibiting ‘Adopter’ behavior when operating abroad in EM. For example, if a DM MNE perceives that the EM environmental laws are less comprehensive or strict, or that the penalties for breaking them are less severe in EM, a DM-headquartered MNE may exhibit a higher level of CO₂ emissions when operating in EM (i.e., one that is closer to the EM norm) than it does when operating in a DM country. Importantly, higher CSI when operating abroad may also be due to less nefarious reasons such as weaker managerial quality or limited resources in foreign affiliates (Strike et al., 2006).

H1a When operating abroad, developed market MNEs either export the CSI norm of their DM headquarters or adopt the CSI norm of their EM host.

EM MNEs may also be exporters or adopters of CSI when operating abroad. EM MNEs (1) must work extra hard to overcome the perceived negative risks associated with their EM COO in order to maintain their ‘right to do business’ in developed markets, and (2) understand that the risks of non-compliance (legal, financial, and reputational) could be catastrophic, there is a strong incentive for EM MNEs to maintain better ESG standards of behavior when operating abroad in developed markets. While the majority of literature expects EM MNEs will be ‘adopters’ of the higher quality ESG standard of their developed market hosts for the reasons just noted (Fiaschi et al., 2017; Zyglidopoulos et al., 2016), there is very little discussion regarding the potential for EM-headquartered firms to export a poorer standard of ESG behavior when operating abroad in DM. Nonetheless, this outcome is possible and there is anecdotal evidence to support that it does happen. For example, there has been a notable increase in media reports related to the misuse of personal data, violation of patent regulations, and international trade agreements by EM MNEs when operating in DM. One of the largest scandals involves a Chinese telecommunications conglomerate that faces numerous indictments of governance related misconduct in US courts.⁶

H1b When operating abroad, emerging market MNEs either export the CSI norm of their EM headquarters or adopt the CSI norm of their DM host.

⁶ <https://www.justice.gov/opa/pr/chinese-telecommunications-conglomerate-huawei-and-subsiaries-charged-racketeering>

Because DM MNEs may seek to exploit easier conditions in certain ESG regulations (i.e., lower workplace safety requirements), the DM CSI norm when operating abroad is expected to be significantly influenced by EM host norms. Likewise, because EM MNEs may rely on good or strong CSP as part of their ‘license to do business’ in DM, the EM CSI norm when operating abroad will likely be influenced by DM host norms. That said, there are reasons to expect CSI home norms will also have an influence on CSI norms abroad. One source of home influence is corporate culture. This source of influence is discussed in management literature as a strategic business decision where DM MNEs choose to mimic their traditional business strategies when operating abroad, thereby creating a ‘global strategy’ (Wright et al., 2005). Strike et al. (2006) note that US MNEs in particular may seek to develop a competitive advantage by building strong, socially responsible reputations according to US standards. Coke and McDonalds are frequently mentioned as examples of this approach to exporting DM ESG behavior norms when operating abroad.

H2a Both DM CSI home norms and EM CSI host norms are expected to influence DM MNE CSI when operating abroad in EM.

H2b Both EM CSI home norms and DM CSI host norms are expected to influence EM MNE CSI when operating abroad in DM.

III.3 Sources of Difference in CSI Norms

Sources of difference in CSI behavior scores when operating at home and abroad are likely to come from a variety of underlying factors that relate to all four subcomponents (environmental, social, governance, cross-cutting as described in Section IV.1. Data Sources below). For example, a known or perceived lower burden of environmental regulations (i.e.,

CO₂ emissions, water quality, etc.) may be one of the ways a DM-headquartered firm can improve its profit margins by expanding into an emerging market. Similarly, differences in social norms (i.e., child labor laws, gender diversity expectations, worker safety, etc.) in some emerging markets may incentivize DM-headquartered companies to exploit these differences to attain a competitive advantage on labor costs. Anecdotally, one might expect governance behavior to contribute the least to the difference in CSI behavior for DM-headquartered firms. One could assume that because developed market MNEs have well-developed management teams that manage the firm's global strategy and operations, developed market MNEs are likely to exhibit similar qualities of governance regardless of when operating at home or abroad (Wright et al., 2005). Nevertheless, the presence of local management teams (i.e., emerging market sourced) to handle day-to-day operations suggests governance will still contribute somewhat to the difference in the CSI norm at home and abroad.

H3a The difference in DM CSI norms at home and abroad is due to some combination of environmental, social, governance, and cross-cutting behavior.

Recognizing that ESG standards generally are likely to be different if not stricter in a developed market host country, all four subcomponents, E, S, G, and CC, are likely to contribute to the difference in CSI behavior for EM MNEs when operating at home in EM versus abroad in DM. However, contrary to the explanation above for DM MNEs (expecting less of the difference to be associated with issues of governance), EM MNEs are likely to have much better governance records when operating abroad in DM. In practice, one of the main sources of difference between the credit quality of EM and DM firms (due to COO) is governance, with EM assumed to have lower quality.

H3b The difference in EM CSI norms at home and abroad is due to some combination of environmental, social, governance, and cross-cutting behavior.

III.4 Changes in CSI behavior Over Time

The increase in public interest and investor activism, surge in ESG-related capital flows, and nascent development of public policies to guide the ESG behaviors of firms, all suggest CSI scores have changed materially over the 14-year sample period. Specifically, the increased public and private scrutiny suggests firms may be more sensitive to the negative reputational and financial impacts from CSI than they were in the past. In this way, one can reasonably expect that firms should be exhibiting less CSI over time.

H4 CSI norms have begun to improve in both emerging and developed markets.

Regarding the subcomponent source of change in CSI norms, an increased awareness around climate change and the global desire to reduce CO2 emissions suggests environmental incidents may have improved the most. Similarly, a growing focus on equal pay, race and gender diversity, and other labor and workplace issues has likely resulted in fewer or less-severe social incidents and thus an improvement in social norms. Conversely, because there has existed a longer and consistent focus on good governance, even in non-ESG investing, there may not be as much improvement in governance-related irresponsibility over time.

H5 Environmental and Social irresponsibility norms are expected to show improvement over time, while Governance norms are expected to show little variation.

After determining whether CSI and subcomponent norms are improving over time in emerging and developed markets, the next question that arises is which firms (domestic or

multinational) are responsible for the improvement or lack of improvement. Lacking evidence from literature and practice about how EM or DM headquartered firms may be altering their CSI behavior at home and abroad over time, I address this gap by analyzing the patterns of CSI and subcomponent norms over time rather than formulating specific hypotheses.

P1 Examines CSI norms over time for EM and DM incident locations, separated by market of headquarters.

P2 Examines the E, S, G and CC norms over time for EM and DM incident locations, separated by market of headquarters.

IV DATA SOURCES & VARIABLE CONSTRUCTION

IV.1 Data Sources

Practitioners and academics alike have largely relied upon third-party ESG ratings from companies such as MSCI, Sustainalytics, and Thomson ASSET4. Ratings from these sources are often substantially based on company provided information from websites, 10-Ks, annual reports, proxy statements, and CSR reports. Further, prospective ratings are sometimes shared and “companies are invited to participate in a formal data verification process”.⁷ These two practices – using company-sourced inputs and allowing company feedback before ratings are finalized – introduce the possibility for self-reporting bias. As such, one can consider these ratings more reflective of a firm’s *claim* about the quality of its ESG practices than the firm’s *actual* ESG-related behavior. Setting aside the possibility for malintent (commonly referred to as ‘greenwashing’), common sense tells us that a claim about one’s behavior may be very different from actual behavior. Further, the fact that some ratings methodologies have changed over time is a potential source of construct validity (Dorfleitner et al., 2015).

Data for this research comes from RepRisk, an independent third-party ESG data provider headquartered in Zurich, Switzerland. RepRisk’s approach has been consistent since its inception and is different from ESG rating providers because it excludes self-reported information and data. Specifically, “Born out of credit risk management, the purpose of RepRisk’s dataset is not to provide ESG ratings, but to systematically identify and assess material ESG risks. We have always taken an outside-in approach to ESG risks, by analyzing

⁷ MSCI ESG Ratings Methodology | April 2020

information from public sources and stakeholders and intentionally excluding company self-disclosures.”⁸

The raw data provided by RepRisk is a time series of publicly reported, ESG-related incidents of regulatory violations or irresponsible behavior. Each incident is coded by (1) the firm or firms involved in the incident, (2) up to 28 ESG-related principles the incident violates, and (3) the country or countries the incident impacts. Artificial intelligence does the initial screening of the incident report, which is then verified and scored by human analysts. Analysts score each incident across three dimensions: severity, reach, and novelty. Severity can have a value of 1, 10, 100 with 100 being the worst, and is an indication of the negative impact or harshness of the event. Reach can take a value of 1-3, with 3 being the greatest reach, and is based on the publication’s circulation. Lastly, novelty takes a value of 1 if it is the first time the incident has been reported and 2 if it is a repeat reporting. Incidents are recorded once when the event takes place and only recorded subsequently if (1) it is escalated to a more influential source, (2) it appears again after six weeks, or (3) additional issues emerge.

This raw data is converted into an incident score that ranges from 1-100. I provide a brief description here, but the score documentation is available from RepRisk⁹. Because a firm’s ESG riskiness is assumed to rise exponentially, incidents are transformed into a geometric mean using the three sub-scores as exponents as follows:

$$\text{Geometric Incident score} = \sqrt[3]{(\exp(\text{Severity Level}) \times \exp(\text{Reach Level}) \times \exp(\text{Novelty Level}))}$$

⁸ <https://www.reprisk.com/approach#why-reprisk>

⁹ <https://www.reprisk.com/>

Each new ESG incident assigned to a company is added to any prior ESG score, but the prior score is assumed to have decayed exponentially to zero over two years. These raw scores are then scaled to 1-100 using an exponential cumulative distribution function to account for the fact that (1) larger companies will have more violations and be more actively reported, (2) over time there seems to be a general increase in incident violations or reporting¹⁰. As such, higher scores indicate worse ESG-related behavior and lower scores indicate behavior that is less-bad. Given the nature of the data (ESG-related violations or irresponsible behavior), good ESG-related behavior is not indicated. This scoring process is run at the overall ESG-level as well as four subcomponents, E, S, G, and CC. Table 1 provides RepRisk’s categorization of the 28 ESG-related principles (to which incidents are coded when violated) within the E, S, G, and CC subcomponents.

[Insert Table 1]

a. Unit of Analysis

Based on the country where the incident took place, the firm-level incident scores described above are aggregated into developed and emerging market averages for each day in the sample (January 2, 2007 through July 31, 2020).¹¹ Market designation for each country follows the International Monetary Fund’s World Economic Outlook (WEO) classification. For the purposes of this research, the IMF’s ‘Advanced Economies’ are coded as DM countries, while ‘Emerging Market and Developing Economies’ are coded as EM countries (see Table 2 for the complete list of DM countries and Table 3 for EM countries). For example, all scores

¹⁰ <https://www.reprisk.com/>

¹¹ Countries are identified as Emerging or Developed based on the classification used in the IMF’s World Economic Outlook report and database. The countries for each market are listed in Table X in the Appendix.

for firms with ESG-related violations in an emerging market country on May 30, 2008 are averaged into the emerging market CSI score on May 30, 2008. As such, the mean of the CSI EM variable represents the ‘norm’ (defined as usual, typical, or standard) level of CSI in emerging markets for the sample period. As a result, the unit of analysis is defined by date (subscript t , day) and market (subscript i , DM or EM).

b. Variable Construction

The primary set of variables are average CSI scores and subcomponent E, S, G, and CC scores attributed to each market (DM and EM). For example, CSI_EM is a time series of the average scores (with a value 0-100) for all ESG-related incidents that occur in an emerging market country, while E_EM is a time series of the average scores for only the Environmental incidents occurring in an emerging market country. In this manner, each variable is designed to represent the ‘norm’ level of CSI for a certain ESG-related incident type, in a specific market location (Emerging or Developed).

		Location of ESG Incident	
		Home	Abroad
Firm HQ	DM	DM_DM	DM_EM
	EM	EM_EM	EM_DM

Figure 3: 2x2 Matrix of Behavior Norms

Variables that represent ‘CSI norms’ are calculated based on a 2x2 matrix using the same EM/DM market classification for the location of the ESG incident and firm headquarters. In Figure 3 at right, the four CSI norms in the center follow the naming convention whereby the prefix identifies the market of firm headquarters and the suffix the location of the ESG-related

incident. Given this convention, scores are calculated at the topline CSI level as well as for the four subcomponents for each of these four main variable types. The naming convention for the final variables is *HQ_Location_Subcomponent*. For example, *DM_EM_G* is the mean score for all incidents incurred by a DM-headquartered firm (i.e., Apple, Volkswagen), occurring in an emerging market (i.e., China, Mexico), that violate a governance principle (i.e., fraud, tax evasion). This is designed to represent the governance norm for DM firms when operating in EM. Importantly, MNEs are represented in both the abroad and home norms. A complete list of variables and their definitions is available in Table 4 in the Appendix.

IV.2 Background/Summary Statistics

I begin my analysis by examining the CSI in EM and DM without regard for the market headquarters for the perpetrator of the CSI. The summary statistics shown in Table 5 demonstrate that across all incident types, the mean CSI scores are lower in DM than in EM. The highest mean CSI score in developed markets is for cross-cutting violations, while the highest mean CSI score in emerging markets is for social violations.

[Insert Table 5]

A paired-samples *t*-test was conducted to determine if the mean CSI and subcomponent scores for DM are significantly different from those for EM. The results shown in Table 6 establish that CSI and subcomponent irresponsibility scores are significantly lower (i.e., better) in DM than in EM. This result supports the general expectation for these two markets, i.e., that similar to credit quality, EM CSI is worse than DM CSI, on average.

[Insert Table 6]

V FINDINGS

Having established that there is a significant difference in CSI scores in EM and DM, the next section analyzes how domestic and foreign firm mean scores compare to the CSI norms in each market location.

V.1 CSI Behavior Types – Adopter or Exporter

First, I examine the mean CSI scores based on the 2x2 matrix. As shown in Figure 4 at right, and in the Summary Statistics in Table 7, DM-headquartered firms behave worse when operating abroad in EM versus their CSI norm at home and EM-headquartered firms appear to behave better when operating abroad in DM versus their CSI norm at home. While this directional difference in CSI scores at home and abroad is large and contextually supported by extant literature, the similarity in CSI norms when operating at home for both market headquarters (DM 46.53 and EM 46.64) is both remarkable and unanticipated. When examining the subcomponent norms, similar home-abroad patterns for DM and EM are found, as shown in the 2x2 matrix in Figure 5 below. For all subcomponents, DM-headquartered irresponsibility norms are much higher when operating abroad versus at home, while EM-headquartered irresponsibility norms are lower when operating abroad versus at home.

		Location of ESG Incident	
		Home	Abroad
Firm HQ	DM	46.53	55.70
	EM	46.64	43.18

Figure 4: Mean CSI Score

		Location of ESG-related Incident							
		Environmental		Social		Governance		Cross-Cutting	
		Home	Abroad	Home	Abroad	Home	Abroad	Home	Abroad
Firm HQ	DM	40.44	52.26	42.03	54.65	43.17	50.83	44.01	52.91
	EM	45.43	43.18	45.42	41.00	42.90	42.13	43.59	41.27

Figure 5: 2x2 Matrix of Subcomponent Norm Scores

[Insert Table 7]

To test hypotheses 1a and 1b, paired-samples *t*-tests were conducted to analyze (a) the DM CSI norm when operating abroad to both the DM home and EM host norms, and (b) the EM CSI norm when operating abroad to both the EM home and DM host norms.

$$DM_EM_CSI_{abroad} \text{ vs. } DM_DM_CSI_{home}, \text{ and vs. } EM_EM_CSI_{host} \tag{1a}$$

$$EM_DM_CSI_{abroad} \text{ vs. } EM_EM_CSI_{home}, \text{ and vs. } DM_DM_CSI_{host} \tag{1b}$$

The paired-samples *t*-tests in Table 8 show that when operating abroad DM-headquartered scores are significantly higher than both their home and host norms, and EM-headquartered scores are significantly lower. As suggested in the discussion of the summary statistics above, there is not a significant difference in the CSI norms for DM- and EM-headquartered firms when operating at home.

[Insert Table 8]

Because there is not a significant difference between the CSI home norm scores, it is technically impossible for either DM- or EM-headquartered firms to behave as ‘adopters’ or ‘exporters’ of their CSI home norms when operating abroad as proposed by the behavioral

model. Therefore, I must reject Hypothesis 1a and 1b that DM and EM firms adopt their host market CSI norms or export their home market CSI norms. However, given that DM-headquartered firms behave worse when operating abroad in EM, and EM-headquartered firms behave better when operating abroad in DM, it is plausible that both are adopting the *perceived* CSI qualities of their host market (i.e., higher standards of ESG behavior in DM, and lower in EM). Figure 6 spatially depicts the results for the 2x2 matrix of CSI norms; the prefix indicates the market headquarters, while Home and Abroad indicate the location of the CSI.

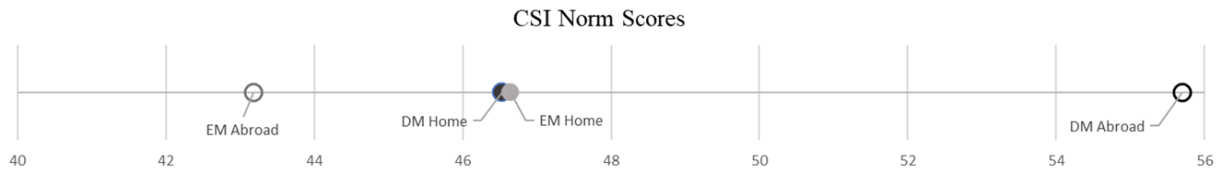

Figure 6: Schematic of CSI Behavior Types

Though not part of the original hypotheses, the same analysis is performed for the subcomponent E, S, G and CC scores. The summary statistics are shown in Table 9 and results from the paired samples *t*-tests are in Table 10, both in the Appendix. The subcomponent irresponsibility norms are spatially depicted in Figure 7 below, followed by a brief summary of the findings.

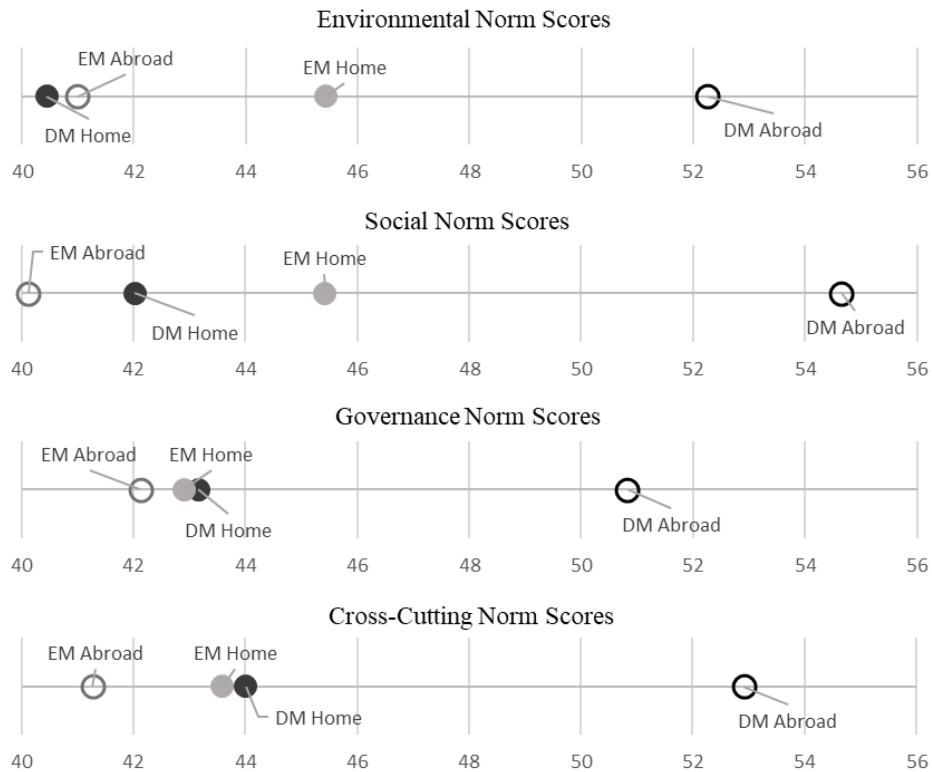

Figure 7: Schematic of Subcomponent Behavior Types

- **Environmental:** EM headquartered firms adopt, but do not exceed the better CSI norm of their DM host. DM headquartered firms adopt and exceed the poorer CSI norm of their EM host.
- **Social:** EM headquartered firms adopt and exceed the better CSI norm of their DM host. DM headquartered firms adopt and exceed the poorer CSI norm of their EM host.
- **Governance & Cross-Cutting:** DM home scores are significantly *higher* than EM home norms. Because of this change in relative positioning for home scores, EM headquartered firms export and exceed their better EM CSI home norm when operating in their DM host. DM headquartered firms export and exceed their poorer DM CSI home norm when operating in their EM host.

Notably, as evident in Figure 7, the worst CSI norms across all subcomponent scores are attributed to DM-headquartered firms when operating abroad in EM. Conversely, for all but the Environmental subcomponent, EM-headquartered firms have the ‘least-egregious’ CSI norms when operating abroad in DM.

Next, I test the hypotheses that both *host* and *home* CSI norms influence the CSI of MNEs when operating abroad. Using linear regression analysis, I regress the CSI score when operating abroad on two independent variables, CSI scores for the home and host markets. This analysis is performed for DM-headquartered firms operating in EM (2a) and EM-headquartered firms operating in DM (2b).

$$DM_EM_CSI_{it} = \alpha_1 + \beta^1_1(DM_DM_CSI_{it}) + \beta^2_1(EM_EM_CSI_{it}) + \varepsilon_{it1} \quad (2a)$$

$$EM_DM_CSI_{it} = \alpha_2 + \beta^1_2(DM_DM_CSI_{it}) + \beta^2_2(EM_EM_CSI_{it}) + \varepsilon_{it2} \quad (2b)$$

The results of the regression analysis and *t*-statistics of the coefficient are reported in Table 11. For both DM- and EM-headquartered firms operating abroad (Panels A and B, respectively), CSI home norms and CSI host norms contribute positively and significantly to the CSI norm when operating abroad and are jointly non-zero. For DM-headquartered norms, CSI *home* norms contribute 2.5 times as much to the variance in CSI when operating abroad than do host norms, whereas for EM-headquartered firms there is no significant difference between the contributions from home and host CSI norms. While the literature suggests home influence on DM-headquartered firms may result in *better* ESG-related behavior in subsidiaries abroad versus the host norms, as part of a strategic business decision, these results suggest a more nefarious though still strategic reason may be at work. A practical example of this result might occur if a DM-headquartered textile firm that relies on cheap labor for its competitive advantage and exhibits social irresponsibility at home (i.e., gender discrimination, poor working conditions) exploits the same social violations but to a greater degree when operating abroad in EM.

[Insert Table 11]

Though not part of the original hypotheses, the same analysis is performed for the subcomponent Environmental, Social, Governance and Cross-Cutting scores to determine which market norms (home or host) influence the subcomponent norms for MNEs when operating abroad. The results of the regression analysis and *t*-statistics are reported in Table 12 in the Appendix. For both markets and across all subcomponents, home and host norms exhibit statistically significant, different, and jointly non-zero effects on CSI norms when operating abroad. Notably for DM MNEs, the size of the coefficient for *home* irresponsibility for social, governance, and cross-cutting is double or more than the size of the coefficients for the *host* norms. This suggests that DM MNEs behavior abroad for these subcomponent behaviors is much more influenced by their patterns of behavior at home. The opposite holds for EM MNEs when it comes to their environmental and social irresponsible behavior abroad, which is significantly more influenced by their DM *host* irresponsibility norms than their home norms. A potential reason for this is the presence of stricter or better defined environmental and social regulations for firms operating in developed markets.

V.2 Sources of Difference in CSI Scores at Home and Abroad

Next, I test the hypotheses that all subcomponents contribute to the *difference* in CSI norms at home and abroad for DM- and EM-headquartered firms (hypotheses 3a and 3b, respectively). For this analysis, I calculate five new variables for DM- and EM-headquartered groups. The dependent variable for both market headquarters is the difference between the CSI scores at home and abroad and is calculated as *Score Abroad – Score at Home*. This way, positive scores indicate higher CSI when operating abroad versus at home. The four independent variables are the difference between the subcomponent scores (E, S, G, and CC) at home and abroad calculated in the same manner. The naming convention is

‘Headquarters_DIFF_Subcomponent’ (i.e., EM_DIFF_S is the mean social score for EM-headquartered firms when operating abroad minus the mean social score when operating at home). The summary statistics for these ‘difference’ variables, shown in Table 13, suggest that CSI trends uncovered in the prior section hold for the subcomponents. Specifically, DM-headquartered firms behave *worse* across CSI and subcomponent E, S, G, and CC score types when operating abroad in EM than they do at home in DM, and EM-headquartered firms behave *better* when operating abroad in DM than they do at home in EM. The higher DM CSI scores when operating abroad suggests DM MNEs are on average taking a local versus global approach for their ESG/CSR strategies (Wright et al., 2005).

[Insert Table 13]

To determine the degree of influence from the subcomponents, I use OLS linear regression analysis to regress the dependent variable (the difference in mean CSI scores when operating at home and abroad) on the four independent variables (the difference in scores at home and abroad for all four subcomponents E, S, G, and CC). This analysis is performed for DM-headquartered firms operating in EM (3a) and EM-headquartered firms operating in DM (3b) as follows.

$$DM_DIFF_CSI_{it} = \alpha_3 + \beta_3^1(DM_DIFF_E_{it}) + \beta_3^2(DM_DIFF_S_{it}) + \beta_3^3(DM_DIFF_G_{it}) + \beta_3^4(DM_DIFF_CC_{it}) + \varepsilon_{it} \quad (3a)$$

$$EM_DIFF_CSI_{it} = \alpha_4 + \beta_4^1(EM_DIFF_E_{it}) + \beta_4^2(EM_DIFF_S_{it}) + \beta_4^3(EM_DIFF_G_{it}) + \beta_4^4(EM_DIFF_CC_{it}) + \varepsilon_{it} \quad (3b)$$

The results of the regression analysis and *t*-statistics of the coefficients are reported in Table 14, and tests of difference in coefficients in Table 15. For both DM- and EM-

headquartered firms operating abroad (Panel A and B, respectively), the difference in all subcomponent scores contribute positively and significantly to the difference in CSI scores when operating abroad versus at home and are jointly non-zero. For DM-headquartered firms, the greatest contributor to the variance in the difference in CSI scores at home and abroad comes from the difference in Cross-Cutting and Social scores. For EM-headquartered firms, the greatest contributor to the variance in CSI scores at home and abroad comes from the difference in Cross-Cutting scores, followed by Governance scores. For both market locations, DM and EM, the lowest contribution comes from the difference in Environmental scores.

[Insert Table 14]

[Insert Table 15]

While the significance of the independent variables supports hypotheses 3a and 3b, the relative size of the coefficients is somewhat surprising. For DM-headquartered firms, the influence from the difference in Social scores is supported by anecdotal evidence and academic theory that DM-headquartered firms often expand into emerging markets specifically to exploit differences in labor markets, working conditions, etc. The strong influence from a difference in Cross-Cutting irresponsibility may be explained by an examination of the types of violations within the Cross-Cutting subcomponent. A simple incident count shows that two of the five CC violation types increase strongly when DM MNEs operate abroad: there is a 252% increase in ‘violations of international standards’ and a 154% increase in ‘supply chain issues’ over the sample period. Both of these types of violations could be considered to fit the anecdotal expectations that DM-headquartered firms are expanding into emerging markets to gain a specific competitive or cost advantage. While the difference in Environmental scores contributed very little to the variance in the CSI scores at home and abroad for DM-

headquartered firms, the lack of contribution may be due to the *consistency* in greater CSI for DM MNEs when operating abroad. In this case, four of the seven Environmental violations show incident count increases of 80% or more when operating abroad.

A look at the incident counts by violation type within each subcomponent may also provide potential contextual color for the regression results for EM-headquartered firms. The general pattern across the 28 violation types suggests that EM-headquartered incident counts *fall* by roughly 75%-85% when operating abroad in DM. The most notable differences occur in the Cross-Cutting and Governance subcomponents, which have the largest coefficients in the regression analysis (equation 3b, above). Within the Cross-Cutting subcomponent, the incident counts of one violation ('products - health and environmental issues') fall by just 62%. This may be an indication that DM product standards may be higher and therefore harder to meet for some EM producers. In the Governance subcomponent, incident counts for three violations (tax evasion, tax optimization, and misleading communications) fall by less than the other violation types (approximate declines of 65% versus 75-80%). The lack of consistently lower scores in these subcomponents may be part of the higher contribution to the variance from Governance scores at home and abroad for EM-headquartered firms. Taken together, the higher coefficients for home influence and greater contribution to variation in the home-abroad difference coming from Governance and Cross-Cutting violations, is well-supported anecdotally, in practice and in the COO literature: EM firms are widely considered to have weaker governance than DM firms.

V.3 Changes in CSI Over Time

This section seeks to identify improvement in CSIs over time by market of incident location and subcomponent of CSI. In order to identify discrete changes in mean scores, the

sample period (January 1, 2007 to July 31, 2020) was divided into four equal parts, t_1 through t_4 .

First, I test to see if CSI norms in DM and EM have improved over time. In order for Hypothesis 4 to be true:

Difference between $CSI_DM_{t_x}$ and $CSI_DM_{t_{x-1}}$ is <0 and statistically significant

and

Difference between $CSI_EM_{t_x}$ and $CSI_EM_{t_{x-1}}$ is <0 and statistically significant (4)

Contrary to expectations for a reduction in CSI norms, the summary statistics for the mean CSI scores at time t_1 , t_2 , t_3 , and t_4 for each market incident location (shown in the top half of Table 16) suggest CSI norms continue to rise throughout the sample period for both DM and EM. Statistical analysis (noted below and shown in the bottom half of Table 13) leads me to reject Hypotheses 4 that CSI norms have improved. Specifically, difference in mean scores for each time period are statistically significantly positive (>0) in all periods for both DM and EM, except for t_4 which shows the difference in EM CSI mean versus t_3 is positive, but not significantly. This result suggests that, despite the additional private and public scrutiny, there has been no material improvement in CSI norms over time. However, these results should be viewed with caution. It is also possible that the increased focus on ESG issues has contributed to an increase in scores over time as (1) CSI is reported more often in the press, (2) CSI incidents are being viewed more harshly and thus receive higher scores, or (3) the lack of consistent standards prevents firms from understanding exactly how they should improve their CSP and by what measure CSP is being judged.

[Insert Table 16]

Next, I examine the individual subcomponents of CSI for signs of improvement over time. As a reminder, given the increasing global emphasis on Environmental and Social issues over the past few years, Hypothesis 5 expects Environmental and Social scores to show improvement in both market locations. Further, Hypothesis 5 expects little change in Governance scores and no view is taken on Cross-Cutting violations.

$E_DMt_x - E_DMt_{x-1}$ is <0 and statistically significantly, and

$E_EMt_x - E_EMt_{x-1}$ is <0 and statistically significantly (5a)

$S_DMt_x - S_DMt_{x-1}$ is <0 and statistically significantly, and

$S_EMt_x - S_EMt_{x-1}$ is <0 and statistically significantly (5b)

$G_DMt_x - G_DMt_{x-1}$ is not significant, and

$G_EMt_x - G_EMt_{x-1}$ is not significant (5c)

Summary scores for t_1 - t_4 and Tukey's HSD tests for significant difference in mean score pairs shown in Table 17, demonstrate that as is the case at the CSI score level, expectations for improvement are not borne out in the subcomponent scores for either DM or EM incident locations. Overwhelmingly and with little exception, subcomponent scores continue to rise significantly throughout the sample period for both DM and EM incident locations (see Figure 8). A summary of the important findings is provided below.

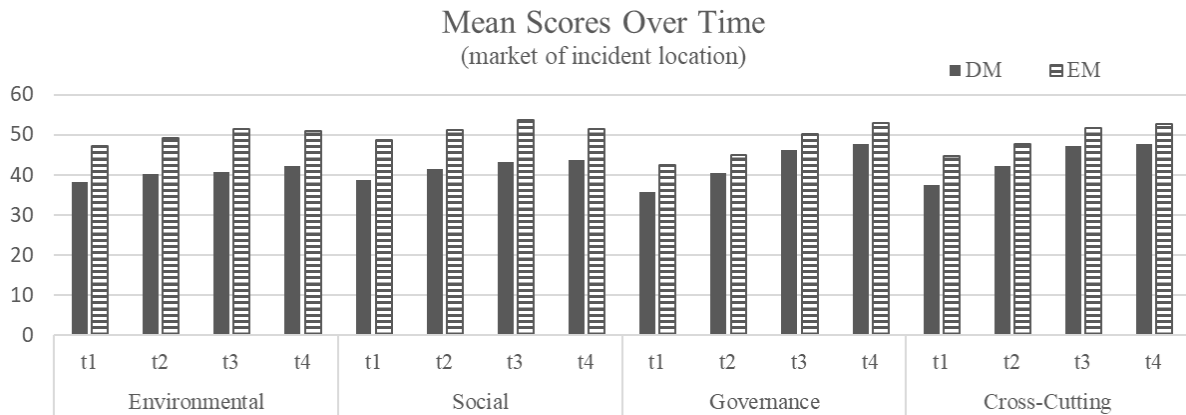

Figure 8: Subcomponent Scores Over Time
[Insert Table 17]

- Hypothesis 5a is rejected as Environmental scores do not show improvement in either market location. That said, Environmental scores in EM may be showing signs of stabilizing as the mean score in t_4 is not significantly different than t_3 .
- Hypothesis 5b is partially accepted as Social scores are statistically significantly lower in t_4 versus t_3 in EM. Social scores in DM continue to rise significantly in t_4 but are increasing at a decreasing rate throughout the sample sub-periods.
- Hypothesis 5c is rejected as, contrary to expectations for stability, Governance scores for both market locations show the largest increase over the sample period and are significantly higher in t_4 versus t_3 for both markets.

Lastly, I examine patterns of CSI over time based on the 2x2 matrix of market headquarters and market incident location. While hypotheses 4 and 5 examine CSI over time in DM and EM incident locations, this pattern analysis shifts the focus to CSI by market headquarters and does not hypothesize about the results. As shown in the summary scores for t_1 - t_4 and Tukey's HSD tests for significant difference in mean score pairs in Table 18, DM-headquartered CSI scores may be showing signs of leveling off (do not significantly increase in t_4) when operating both at home in DM and abroad in EM. Conversely, EM-headquartered CSI scores continue to rise significantly for all sub-periods. One explanation for this may be that EM-headquartered scores are merely catching up with DM-headquartered CSI norms. For example, EM-headquartered mean CSI scores when operating abroad in DM in period t_1 are

36.6, while the DM host mean scores are 40.0. As the DM host mean scores rise throughout the sample period, EM-headquartered scores when operating abroad in DM appear to catch up. This pattern (shown in Figure 9 below) may be explained by EM-headquartered firms realizing that they did not need to bear the cost and burden of maintaining a higher ESG standard than the ESG standards of domestic firms operating in DM. And when operating at home, EM-headquartered firms may also be reducing their ESG quality as they witness DM-headquartered firms operating in EM “getting away with” a lower standard of ESG-related behavior.

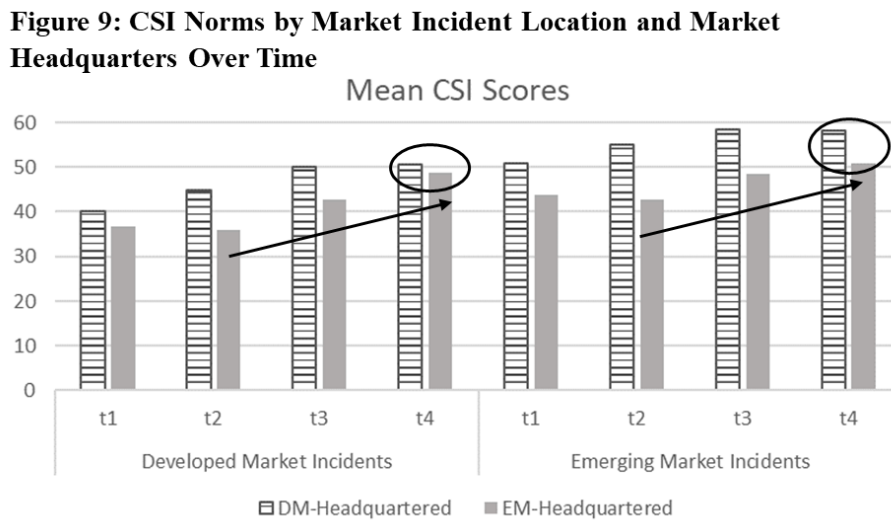

Figure 9: CSI Norms by Market Incident Location and Market Headquarters Over Time
 [Insert Table 18]

Finally, Table 19 shows the summary scores for t₁-t₄ and Tukey’s HSD tests for significant difference in mean score pairs for subcomponent scores (E, S, G, and CC) by the 2x2 matrix of market location of incident and market headquarters. A brief summary of the main patterns is provided below.

[Insert Table 19]

- Environmental scores continue to rise in DM, driven by an increase in both DM-headquartered home scores and EM-headquartered abroad scores, but are at a relatively lower level than most other score subcomponents. Environmental scores may be stabilizing in EM as both DM-headquartered (when abroad) and EM-headquartered (at home) scores are not significantly higher in t_4 .
- Social scores appear to be stabilizing for DM- and EM-headquartered firms when operating at home but continue to rise significantly when operating abroad.
- Governance scores are rising significantly for all market headquarters and market incident location pairs. This notable result may suggest that with environmental and social issues increasingly under scrutiny, the rapid globalization and creation of mega-MNEs is pressuring firms into irresponsible governance tactics in the quest for competitive advantage and profits.
- DM-headquartered Cross-Cutting scores may be stabilizing both at home and abroad, but EM-headquartered scores are significantly rising.

c. Robustness Checks

As mean scores may be biased by the presence of outliers, I recalculate the sample mean scores across time using the *median* firm-level score for each date and market incident location. As shown in Figure 9, the mean subcomponent scores (based on the underlying daily median scores) for both DM and EM headquartered firms, both at home and abroad, broadly match the patterns from the original database of mean scores over time with daily underlying firm-level *mean* scores. The notable differences are (1) for both DM and EM headquartered firms, the Governance and Cross-Cutting medians are lower than the means when operating at home, and (2) DM-headquartered median scores are higher than the means across all subcomponents when operating abroad. Nonetheless, the similarity in score patterns and magnitudes reduces the probability that the main findings are unduly influenced by outliers or that using the medians of firm-level scores would materially change the results.

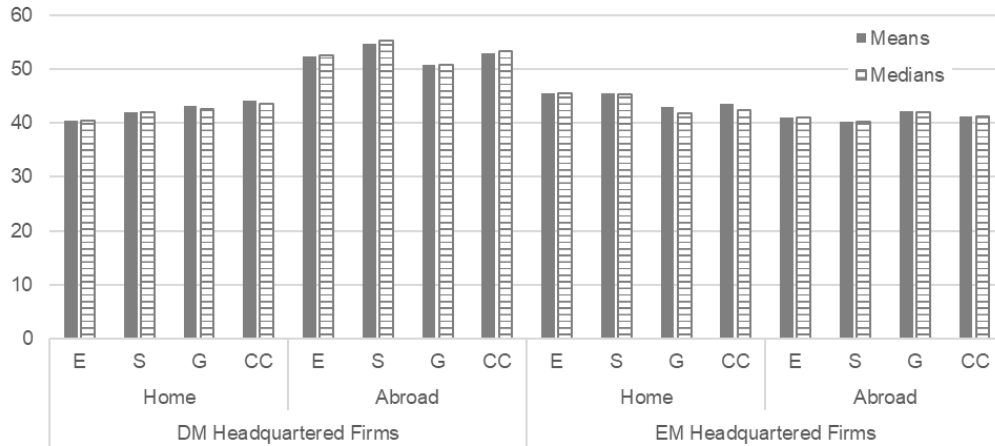

Figure 10: Mean vs. Median Subcomponent Scores

Another potential issue with this data is one of frequency versus magnitude. As example, a country with just 5 incidents each scoring 60 would be perceived as having a worse CSI norm (by either mean or median) than a country with 500 incidents each scoring 50. This influence may also change over time if, for example, the media began to report more frequently on less-severe but increasingly newsworthy CSI. To address this potential issue, I examined the distribution of scores by market headquarters, at home and abroad, and across all time periods. As shown in the histograms in tables 20 and 21 in the Appendix, indicators of skewness are below +/- 1 for both DM and EM, at home and abroad, and across all time periods suggesting distribution of scores are not substantially skewed. Despite the statistical results, a visual inspection indicates that EM-headquartered firms have an outsized frequency of scores in the 20-25 range in t_1 and t_2 . This distribution fades in t_3 and t_4 but remains evident in the full sample. The larger threat to normality is the presence of kurtosis for DM-headquartered firms. Values of kurtosis exceed 1 beginning in t_2 at home and persisting in t_3 and t_4 for scores at home and abroad. Because kurtosis values are below 2 in all but one instance (DM at home, t_4), distributions appear to be normal.

Lastly, there may be an outsized country influence in either market location. Both by headquarters and location of incident, the US is the largest DM incident-count contributor to global CSI and China is the largest EM contributor (refer to Tables 2 and 3 for counts). Because of this, MNEs from these two locations may be largely or disproportionately responsible for the results found in this body of research. To determine if the results would be similar without these influences, I created a new dataset that excludes firms headquartered in the US and China. The patterns, shown in Figure 10 below, for the market-based norms (based on the original firm-level means) across the subcomponents are consistent with the full sample: norms for DM-headquartered firms are higher when operating abroad versus at home, while norms for EM-headquartered firms are lower when operating abroad versus at home. Also consistent with the full sample, EM and DM CSI home norms are not statistically significantly different. That said, there are some notable differences. First, DM norm scores at home are higher when excluding US-headquartered firms but are lower when operating abroad. This suggests US firms may be disproportionately responsible for the difference in scores at home and abroad (they behave much better at home and much worse abroad). Second, EM norm scores are higher across all subcomponents, both at home and abroad, when excluding China-headquartered firms. This suggests China-headquartered firms may be less ‘bad actors’ than popularly characterized. More generally, the incident count data demonstrates that the US has a disproportionate role in CSI incidents from both a headquarters and location perspective, representing 33% and 15% of global CSI incidents, respectively (Table 22). Beyond the US, single country influence appears reasonable as no one country accounts for more than 7% of global incidents by headquarters or location of CSI.

[Insert Table 22]

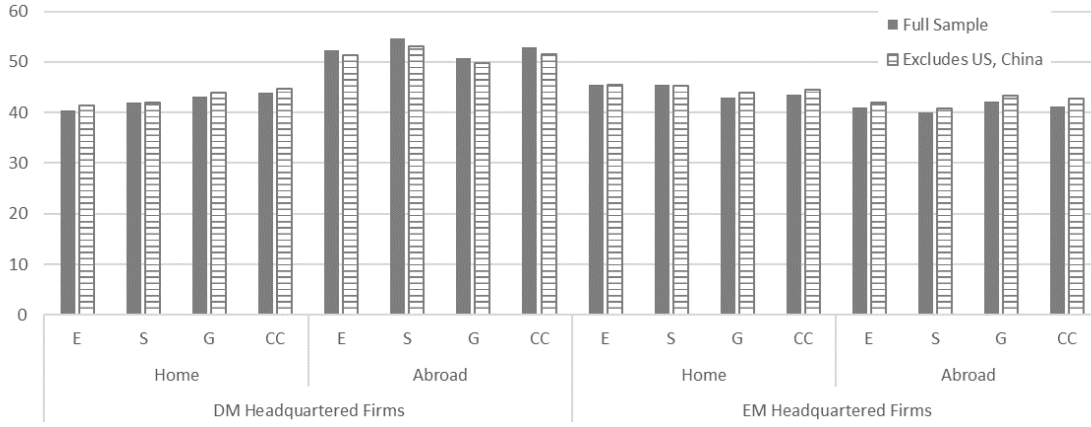

Figure 11: Subcomponent Scores for Full Sample vs. Sample without US and China

VI DISCUSSION

VI.1 Contribution

This research supports practitioner expectations that ESG quality is poorer in emerging markets versus developed markets. It also provides evidence to support the conjectures that developed market firms expand into emerging markets to take advantage of weaker regulations and reduced penalties for irresponsible ESG-related behavior, while emerging market firms maintain better ESG behavior when operating abroad in developed markets to maintain their reputation and ‘license to do business.’ Importantly, this research shows that MNEs from both market headquarters often ‘over-adopt’ the perceived norms of their host market. Because of these extremes, the perception of poorer ESG quality in EM may be largely due to DM MNEs rather than domestic firms, and vice versa. This suggests that the popular notion from practitioners and ESG rating agencies that market-based *ESG quality* patterns mirror *credit quality* patterns (i.e., that EM is poorer and DM is better) may be inadvertently biased. In other words, in practice, an EM-based multinational may be perceived or rated as having a poorer ESG quality based unfairly on its market headquarters rather than its actual ESG behavior or impact. And DM-based multinationals may garner higher third-party ESG ratings when positive and negative ESG activities are netted and consequently obscure the downside risk signals from DM MNE’s poorer CSI behavior abroad.

Regarding the subcomponents of CSI, environmental and social irresponsibility tends to be lower than governance and cross-cutting irresponsibility. Similarly, irresponsible environmental and social behaviors may be leveling off, while governance and cross-cutting behavior continues to worsen. This suggests that the increased attention from both the public and regulatory bodies regarding environmental and social issues may be working to achieve

less irresponsible behavior in these areas by firms around the world. It also suggests that less focus by the public, policymakers, and academics may inadvertently be contributing to firms' willingness to act irresponsibly on issues of governance. This result is particularly important in light of the findings by Dimson et al. (2015), which finds that financial market reaction is positive after successful engagements on issues of corporate governance and Dyck et al. (2010), which finds that the media can act as an effective whistle-blower for corporate fraud. Lastly, it highlights that governance remains a major area of weakness and should not be left out of academic research which often focuses solely on environmental and social issues. Lastly, this finding may be particularly useful for practitioners (i.e., investors) looking to effect change, especially in light of recent research on the effectiveness of coordinated engagements and CSP outcomes (Dimson et al. 2020).

Finally, globalization may be leveling the playing field for EM-headquartered MNEs. After years of outperforming on ESG metrics to overcome the negative perceptions based on their country-of-origin and watching their DM-headquartered peers behave more irresponsibly but with seemingly less reputational, if not financial and regulatory consequence, EM-headquartered firm irresponsibility norms are aligning with their DM peers and for the worse, not better. In addition to these EM/DM headquartered trends, this research points out that there is no concrete evidence that ESG quality is materially improving over time. Combined, these findings suggest that a globally coordinated approach by both policymakers and practitioners, as well as thoughtful examination by academics across all aspects of ESG factors, is the best way to ensure ESG quality standards begin to improve for all stakeholders.

VI.2 Limitations & Future Research

There are three main sources of limitation with regard to this research based on what is being measured, the data source, and the market delineations. First, because only irresponsible behavior is being scored, there is a potential issue of truncation in what is being measured. As a result, this data does not measure overall ESG quality, but rather only the negative aspect of ESG behavior. Adding the positive ESG behavior of firms when operating at home and abroad into scores would undoubtedly yield different results. As such, the results of this paper need to be carefully considered and viewed only from the lens of irresponsible ESG behavior norms rather than overall ESG quality.

Second, the data is primarily based on media reports which may introduce unintended bias. Generally, media bias may cause scores to be higher or lower based on either the location of the CSI incident or location of headquarters. For example, scores may be artificially lower in EM if ESG-related stories are not as newsworthy and thus less reported (bias of omission), or artificially higher if there is a lower standard for reporting (allowing for more unsubstantiated claims of bad behavior to be reported). In DM, media and NGO reports that rely on sensationalism or ‘mudslinging’ to increase readership or obtain global attention may target or report more often on certain industries or MNEs (i.e., well-known DM-headquartered global brands or large energy firms).

Third, there are also likely significant EM/DM and regional differences in ESG sensitivities and therefore the threshold for newsworthiness of CSI incidents. These differences undoubtedly influence media reporting patterns based on the ESG-related topics covered, the reporter’s perception of severity, frequency, etc. More broadly, to the extent that much of the scores may be based on Western press articles, incidents could be biased by Western ideals of

acceptable ESG behavior (Gugler & Shi, 2009). Finally, while using EM/DM market delineations aligns well with investment practitioners, there are likely many ESG-related differences between the regions and countries that comprise each market group and this lack of homogeneity may skew the data.

Another limitation is the time span of the sample. While spanning a longer time period than much of the extant literature should help illuminate patterns of change, the rapid evolution in ESG constructs and regulations as well as the practice of sustainable finance introduces uncertainty regarding the consistency of the findings over time. In this way, the lack of significant improvement in CSI may be due to factors other than malice. For example, because regulations are still not comprehensive or uniform, firms may not know exactly what is expected of them to demonstrate responsible ESG behavior. Or, because of the increase in public interest, media reporting may be getting harsher. This may be evidenced by the fact that incident counts have gone down in the most recent period, but mean CSI scores have generally not improved. Relatedly, the media biases noted above are also likely changing with time. As such, the results in section V.3 Changes in CSI Over Time should be viewed cautiously.

Future research could be designed to address some of the data and market issues noted above but could also delve further into claims versus behaviors or specific ESG variables. For example, to help answer questions relating to greenwashing, it would be interesting to examine firm claims (CSR reports or third-party ratings) versus public reports of behavior (using RepRisk data or other measures of behavior) to identify instances where firms may say one thing and do another. Relating to the subcomponents, it would be interesting to look more closely at the 28 violations of ESG-related principals RepRisk identifies and how these differ by market, region, country, or firm headquarters. And finally, the rising trends in irresponsible

governance behaviors warrant more research. It would be particularly interesting to examine MNE governance irresponsibility with the large body of research on CSP and litigation which suggests that firms would want to export higher CSP to reduce that risk when operating abroad (Fauser & Utz, 2021; Koh et al., 2014).

VII CONCLUSION

With 12,765 firms in 160 countries having committed to responsible and sustainable practices under the UN Global Compact¹², it is critical that practitioners, policymakers, and academics investigate the degree to which these proclamations are bearing fruit. In asking the question “Do multinational enterprises export or adopt Corporate Social Irresponsibility?” I explore patterns of CSI norms in developed and emerging markets based on both market headquarters and location of CSI. I show that while emerging market CSI scores are generally poorer than developed markets, this may be more attributable to the perpetrator of the CSI than the locally accepted CSI norm. Because the evidence shows that environmental and social irresponsible behavior may be leveling off while governance-related irresponsibility is still rising, I also suggest that public and media attention (inattention) may be having a positive (negative) impact on ESG-related behaviors. Finally, I explore changes in CSI over time and find that little improvement is evident to date. From this, I conclude that more time, attention, and focus from global regulators and investors is still required to ensure a more sustainable outcome for future generations.

¹² <https://www.unglobalcompact.org/>

APPENDICES

Appendix A: Tables

Table 1: List of violations by CSI subcomponent

This table categorizes the 28 ESG-related violations into the four CSI subcomponents. The source is RepRisk.

Environmental	Social
Climate change, GHG emissions, and global pollution	Freedom of association and collective bargaining
Impacts on landscapes, ecosystems, and biodiversity	Human rights abuses and corporate complicity
Overuse and wasting of resources	Occupational health and safety issues
Impacts on communities	Discrimination in employment
Animal mistreatment	Poor employment conditions
Local pollution	Local participation issues
Waste issues	Social discrimination
	Forced labor
	Child labor
Governance	Cross-Cutting
Corruption, bribery, extortion, and money laundering	Products (health and environmental issues)
Executive compensation issues	Violation of international standards
Misleading communication	Controversial products and services
Anti-competitive practices	Violation of national legislation
Tax optimization	Supply chain issues
Tax evasion	
Fraud	

Table 2: List of Developed Market Countries

This table identifies Developed Market countries according to the International Monetary Fund's World Economic Outlook. It also shows the number of CSI incidents based on where the incident occurred and the number of CSI incidents based on the headquarters of the firm responsible for the incident. The incident count data is from RepRisk and covers the sample period January 2, 2007 to July 31, 2020.

Developed Market Countries (DM)		
Country	Incident Count by Location	Incident Count by Firm Headquarters
Australia	9,845	4,536
Austria	1,974	728
Belgium	3,529	979
Canada	11,173	10,305
Cyprus	2,418	107
Czechia	2,402	111
Denmark	1,654	968
Estonia	856	118
Finland	1,466	1,317
France	9,312	10,079
Germany	10,381	13,026
Greece	2,385	219
Hong Kong	4,407	1,857
Iceland	173	91
Ireland	3,590	1,036
Israel	4,338	1,422
Italy	7,077	4,564
Japan	7,092	11,458
Korea	16,676	15,688
Latvia	752	67
Lithuania	800	60
Luxembourg	4,020	1,363
Macao	1,293	21
Malta	2,133	23
Netherlands	6,629	5,951
New Zealand	2,298	376
Norway	2,612	1,509
Portugal	1,626	595
Puerto Rico	256	6
San Marino	51	0
Singapore	4,380	1,704
Slovakia	1,130	54
Slovenia	1,249	15
Spain	5,814	4,381
Sweden	2,018	2,697
Switzerland	7,926	9,721
Taiwan	3,204	2,263
United Kingdom	17,978	18,869
United States of America	90,716	90,106

Table 3: List of Emerging Market Countries

This table identifies Emerging Market countries according to the International Monetary Fund's World Economic Outlook. It also shows the number of CSI incidents based on where the incident occurred and the number of CSI incidents based on the headquarters of the firm responsible for the incident. The incident count data is from RepRisk and covers the sample period January 2, 2007 to July 31, 2020.

Emerging Market Countries (EM)								
Country	Incident Count by Location	Incident Count by Firm HQ	Country	Incident Count by Location	Incident Count by Firm HQ	Country	Incident Count by Location	Incident Count by Firm HQ
Afghanistan	400	0	Gambia	261	0	Palau	17	0
Albania	284	0	Georgia	1,775	10	Panama	3,999	53
Algeria	1,368	0	Ghana	2,225	22	Papua New Guinea	2,415	75
Angola	1,750	0	Grenada	27	0	Paraguay	937	15
Antigua and Barbuda	1,295	0	Guatemala	2,335	21	Peru	5,853	482
Argentina	5,519	480	Guinea	968	4	Philippines	6,377	1,213
Armenia	197	0	Guinea-Bissau	6	0	Poland	3,386	304
Aruba	1,190	0	Guyana	275	0	Romania	2,501	43
Azerbaijan	948	95	Haiti	168	0	Russian Federation	10,879	5,130
Bahamas	1,253	2	Honduras	1,383	42	Rwanda	211	2
Bahrain	2,150	50	Hungary	1,971	93	Saint Kitts and Nevis	1,195	0
Bangladesh	5,285	149	India	15,875	6,115	Saint Lucia	1,192	0
Barbados	1,365	15	Indonesia	13,513	1,648	St. Vincent and Grenadines	467	0
Belarus	184	0	Iran	2,180	108	Samoa	822	0
Belize	698	13	Iraq	1,852	6	Sao Tome and Principe	79	0
Benin	509	0	Jamaica	691	7	Saudi Arabia	2,175	202
Bhutan	191	0	Jordan	1,994	104	Senegal	1,556	2
Bolivia	1,402	4	Kazakhstan	2,901	279	Serbia	1,383	22
Bosnia and Herzegovina	1,399	30	Kenya	2,992	214	Seychelles	1,009	0
Botswana	1,380	26	Kiribati	4	0	Sierra Leone	1,341	0
Brazil	19,579	9,707	Kuwait	758	79	Solomon Islands	54	0
Brunei Darussalam	65	0	Kyrgyzstan	212	11	Somalia	261	0
Bulgaria	1,892	43	Lao	2,556	0	South Africa	8,181	2,355
Burkina Faso	483	1	Lebanon	1,496	44	South Sudan	424	0
Burundi	91	1	Lesotho	433	0	Sri Lanka	1,723	67
Cabo Verde	65	3	Liberia	3,160	1	Sudan	2,200	7
Cambodia	3,482	2	Libya	1,272	1	Suriname	117	0
Cameroun	1,791	68	Madagascar	1,308	0	Syrian Arab Republic	845	5
Central African Republic	191	0	Malawi	1,207	7	Tajikistan	606	0
Chad	507	0	Malaysia	6,301	1,877	Tanzania	2,989	19
Chile	4,354	1,124	Maldives	461	0	Thailand	3,881	850
China	28,327	13,862	Mali	903	0	Timor-Leste	202	0
Colombia	6,839	474	Marshall Islands	806	14	Togo	423	40
Comoros	49	0	Mauritania	386	0	Tonga	7	0
Congo	4,530	0	Mauritius	2,508	84	Trinidad and Tobago	110	45
Congo (Democratic Republic)	637	0	Mexico	7,256	1,705	Tunisia	629	27
Costa Rica	1,882	22	Micronesia	13	0	Turkey	4,142	283
Côte d'Ivoire	2,354	128	Moldova	754	95	Turkmenistan	343	0
Croatia	613	60	Mongolia	2,034	9	Tuvalu	2	0
Djibouti	216	0	Montenegro	248	11	Uganda	1,918	17
Dominica	34	0	Morocco	2,719	112	Ukraine	2,844	364
Dominican Republic	2,116	2	Mozambique	3,424	13	United Arab Emirates	2,913	302
Ecuador	3,042	155	Myanmar	3,871	7	Uruguay	944	1
Egypt	2,955	228	Namibia	695	4	Uzbekistan	1,392	2
El Salvador	1,344	3	Nauru	170	0	Vanuatu	56	0
Equatorial Guinea	415	0	Nepal	717	5	Venezuela	2,054	484
Eritrea	237	0	Nicaragua	530	0	Viet Nam	3,713	146
Eswatini	987	6	Niger	779	0	Yemen	924	0
Ethiopia	1,532	0	Nigeria	7,076	660	Zambia	2,689	211
Fiji	122	0	Oman	500	17	Zimbabwe	1,958	71
Gabon	1,145	8	Pakistan	3,699	375			
							96,338	12,839

Table 4: Variables Defined

This table lists and defines the variables constructed for this research.

Mean Score by Score Type and Market of Incident Location:	
<i>CSI_DM</i>	
<i>E_DM</i>	Prefix lists score type (CSI-combined score, E-Environmental, S-Social, G-Governance, CC-Cross-Cutting); DM suffix indicates the market where the behavior incident occurred, a developed market country for these scores.
<i>S_DM</i>	
<i>G_DM</i>	
<i>CC_DM</i>	
<i>CSI_EM</i>	
<i>E_EM</i>	Prefix lists score type (CSI-combined score, E-Environmental, S-Social, G-Governance, CC-Cross-Cutting); EM suffix indicates the market where the behavior incident occurred, an emerging market country for these scores.
<i>S_EM</i>	
<i>G_EM</i>	
<i>CC_EM</i>	
Mean Score by Market Headquarters When Operating at Home, and Score Type:	
<i>DM_DM_CSI</i>	
<i>DM_DM_E</i>	Scores in this group are mean scores for DM-headquartered firms (prefix) with incidents occurring at home in a developed market country (middle code DM). The suffix indicates the score type.
<i>DM_DM_S</i>	
<i>DM_DM_G</i>	
<i>DM_DM_CC</i>	
<i>EM_EM_CSI</i>	
<i>EM_EM_E</i>	Scores in this group are mean scores for EM-headquartered firms (prefix) with incidents occurring at home in an emerging market (middle code EM). The suffix indicates the score type.
<i>EM_EM_S</i>	
<i>EM_EM_G</i>	
<i>EM_EM_CC</i>	
Mean Score by Market Headquarters When Operating at Abroad, and Score Type:	
<i>DM_EM_CSI</i>	
<i>DM_EM_E</i>	Scores in this group are mean scores for DM-headquartered firms (prefix) with incidents occurring abroad in an emerging market country (middle code EM). The suffix indicates the score type.
<i>DM_EM_S</i>	
<i>DM_EM_G</i>	
<i>DM_EM_CC</i>	
<i>EM_DM_CSI</i>	
<i>EM_DM_E</i>	Scores in this group are mean scores for EM-headquartered firms (prefix) with incidents occurring abroad in a developed market country (middle code DM). The suffix indicates the score type.
<i>EM_DM_S</i>	
<i>EM_DM_G</i>	
<i>EM_DM_CC</i>	
Difference in Mean Score at Home and Abroad, by Market Headquarters and Score Type:	
<i>DM_DIFF_CSI</i>	
<i>DM_DIFF_E</i>	Scores in this group represent a difference in mean scores (middle code DIFF) and are calculated as score abroad minus mean score at home. Prefix DM indicates scores are for DM-headquartered firms, suffix indicates the score type.
<i>DM_DIFF_S</i>	
<i>DM_DIFF_G</i>	
<i>DM_DIFF_CC</i>	
<i>EM_DIFF_CSI</i>	
<i>EM_DIFF_E</i>	Scores in this group represent a difference in mean scores (middle code DIFF) and are calculated as score abroad minus mean score at home. Prefix EM indicates scores are for EM-headquartered firms, suffix indicates the score type.
<i>EM_DIFF_S</i>	
<i>EM_DIFF_G</i>	
<i>EM_DIFF_CC</i>	

Table 5: Summary Statistics by Incident Location

This table reports the mean CSI score and mean subcomponent scores for incidents occurring in developed and emerging markets for the sample period January 2, 2007 to July 31, 2020.

	Developed Market					Emerging Market				
	CSI	E	S	G	CC	CSI	E	S	G	CC
#Obs	4808	4751	4752	4590	4746	4830	4769	4803	4640	4769
Minimum	20.23	13.59	16.09	11.58	17.08	17.75	15.22	15.05	17.50	13.34
Maximum	86.22	79.37	74.02	86.38	86.22	92.49	90.17	91.95	92.42	91.34
Mean	46.34	40.42	41.89	43.08	43.86	52.20	49.75	51.30	47.91	49.40
Std. Deviation	7.88	6.68	6.37	8.31	7.50	9.65	9.48	9.46	10.03	9.58

Table 6: Comparing Mean Scores by Market of Incident Location

This table reports the paired-samples *t*-test results for CSI and subcomponent mean scores between developed and emerging market located incidents for the sample period January 2, 2007 to July 31, 2020. Figures market with ***, **, * are significant at the 1%, 5%, and 10% levels, respectively.

	DM scores versus EM Scores				
	CSI	E	S	G	CC
Paired Difference	-6.03***	-9.58***	-9.66***	-4.99***	-5.70***
Std. Deviation	9.82	9.84	9.57	9.76	9.40
T-test	-42.18	-66.15	-68.83	-34.17	-41.26
df	4720	4620	4652	4459	4630

Table 7: Summary Statistics for CSI Scores at Home and Abroad by Market Headquarters

This table reports the mean CSI score by market headquarters, at home and abroad, for the sample period January 2, 2007 to July 31, 2020.

	DM Headquarters		EM Headquarters	
	Home	Abroad	Home	Abroad
#Obs	4,803	4,699	4,541	2,563
Minimum	20.23	17.75	19.82	20.23
Maximum	85.94	95.40	92.31	86.82
Mean	46.53	55.70	46.64	43.18
Std. Deviation	7.94	10.80	11.27	13.51

Table 8: Comparing Mean Scores by Market Headquarters, at Home and Abroad

This table reports the paired-samples *t*-tests for mean CSI scores. Panel A shows *t*-tests for incidents occurring abroad versus home and abroad versus host for DM-headquartered firms, and Panel B for EM-headquartered firms. Panel C compares the mean CSI scores when operating at home for DM- and EM-headquartered firms. All statistics are for the sample period January 2, 2007 to July 31, 2020. Figures market with ***, **, * are significant at the 1%, 5%, and 10% levels, respectively.

	Panel A		Panel B		Panel C
	DM Abroad vs. DM Home	DM Abroad vs. EM Host	EM Abroad vs. EM Home	EM Abroad vs. DM Host	DM Home vs. EM Home
Paired Difference	9.31***	9.23***	-5.47***	-5.39***	0.19
Std. Deviation	10.65	13.01	12.78	13.12	11.98
T-test	59.26	47.10	-21.45	-20.80	1.08
df	4,599	4,409	2,516	2,557	4,458

Table 9: Summary Statistics for CSI and Subcomponent Scores by Market Headquarters and Market of Incident Location

Panel A of this table reports the mean CSI score and mean subcomponent scores for DM-headquartered firms when operating at home and abroad. Panel B reports the mean CSI score and mean subcomponent scores for EM-headquartered firms when operating at home and abroad. All statistics are for the sample period January 2, 2007 to July 31, 2020.

	Panel A: Developed Market Headquartered Firms								Panel B: Emerging Market Headquartered Firms								
	Home (DM)				Abroad (EM)				Home (EM)				Abroad (DM)				
	E	S	G	CC	E	S	G	CC	E	S	G	CC	ESG	E	S	G	CC
#Obs	4746	4745	4588	4743	4603	4659	4493	4635	4365	4448	4141	4383	2563	1926	2102	2237	2387
Minimum	13.59	16.09	11.58	17.08	15.22	15.05	11.45	14.27	10.68	11.50	10.14	10.68	20.23	10.30	8.06	10.14	10.83
Maximum	79.37	74.02	86.03	85.99	91.84	95.00	95.23	92.58	88.92	92.17	92.29	90.44	86.82	78.12	78.23	87.13	86.69
Mean	40.44	42.03	43.17	44.01	52.26	54.65	50.83	52.91	45.43	45.42	42.90	43.59	43.18	41.00	40.12	42.13	41.27
Std. Deviation	6.75	6.44	8.34	7.55	11.09	10.65	11.05	10.69	10.61	10.74	12.06	11.11	13.51	10.28	10.27	13.96	12.99

Table 10: Comparing Mean Scores at Home by Market Headquarters

This table reports the paired-samples *t*-tests for subcomponent mean scores between DM-headquartered and EM-headquartered firms when operating at home for the sample period January 2, 2007 to July 31, 2020. Figures market with ***, **, * are significant at the 1%, 5%, and 10% levels, respectively.

	DM Home vs. EM Home Subcomponent Scores			
	Environmental	Social	Governance	Cross-Cutting
Paired Difference	-4.93***	-3.26***	0.89***	0.89***
Std. Deviation	11.66	11.48	12.28	11.61
<i>t</i> -test	-27.61	-18.73	4.59	5.05
df	4,261	4,339	4,045	4,299

Table 11: CSI Scores Abroad as a Function of CSI Norm Scores at Home and at Host

This table reports the OLS coefficient estimates, test of difference, and t -statistics of equations 2a and 2b using daily data for the sample period January 2, 2007 to July 31, 2020. Panel A regresses the independent variable DM_DM_CSI , representing the DM CSI home norm, and EM_EM_CSI , representing the EM host norm on DM_EM_CSI , representing the DM norm when operating abroad. Panel B regresses the independent variables EM_EM_CSI (EM home norm) and DM_DM_CSI (DM host norm) on EM_DM_CSI , the EM norm when operating abroad. Figures market with ***, **, * are significant at the 1%, 5%, and 10% levels, respectively, and t -statistics are reported in parentheses.

Dependent Variable	Panel A	Panel B
	DM_EM_CSI	EM_DM_CSI
Constant	29.575	-2.73
DM_DM_CSI	0.406*** (21.15)	0.417*** (11.30)
EM_EM_CSI	0.161*** (12.41)	0.528*** (22.38)
Difference	0.244*** (9.53)	-0.111 (-2.29)
Joint Test, F	385.98	395.18
P-value	0.000	0.000
R ²	0.151	0.240
#Obs	4,343	2,512

Table 12: Subcomponent Scores Abroad as a Function of Subcomponent Norms at Home and at Host

This table reports the OLS coefficient estimates, test of difference, and t -statistics using mean subcomponent score when operating abroad as the dependent variable using daily data for the sample period January 2, 2007 to July 31, 2020. For each subcomponent panel, Panel A regresses the independent variables DM home norm and EM host norm on the DM abroad norm, and Panel B regresses the independent variables EM home norm and DM host norm on the EM abroad norm. Figures market with ***, **, * are significant at the 1%, 5%, and 10% levels, respectively, and t -statistics are in parentheses.

	Environmental		Social		Governance		Cross-Cutting	
	Panel A	Panel B	Panel A	Panel B	Panel A	Panel B	Panel A	Panel B
Dependent Variable	<i>DM_EM_E</i>	<i>EM_DM_E</i>	<i>DM_EM_S</i>	<i>EM_DM_S</i>	<i>DM_EM_G</i>	<i>EM_DM_G</i>	<i>DM_EM_CC</i>	<i>EM_DM_CC</i>
Constant	32.192	12.181	30.748	9.580	24.878	-0.512	28.216	1.329
<i>DM_DM_</i>	0.315*** (12.95)	0.406*** (10.02)	0.399*** (16.71)	0.403*** (9.79)	0.442*** (21.77)	0.357*** (9.01)	0.422*** (20.64)	0.361*** (9.16)
<i>EM_EM_</i>	0.168*** (11.27)	0.253*** (10.24)	0.164*** (12.03)	0.279*** (11.80)	0.169*** (13.03)	0.569*** (23.77)	0.15*** (11.48)	0.509*** (21.68)
Difference	0.147*** (4.87)	0.153*** (3.02)	0.235*** (8.03)	0.124** (2.44)	0.273*** (10.07)	-0.212*** (-4.07)	0.272*** (10.12)	-0.148*** (-2.93)
Joint Test, F	169.63	122.02	247.70	139.66	445.91	422.56	358.52	344.81
P-value	0.000	0.000	0.000	0.000	0.000	0.000	0.000	0.000
R ²	0.076	0.115	0.105	0.120	0.185	0.279	0.146	0.228
#Obs	4,119	1,873	4,216	2,051	3,920	2,189	4,181	2,336

Table 13: Summary Statistics for the Difference in Scores at Home and Abroad by Market Headquarters and Score Type

This table reports the mean of the differences in scores (calculated as mean home score minus mean abroad score). The first panel shows the home-abroad difference in mean CSI and mean subcomponent scores for DM-headquartered firms and the second panel shows the home-abroad difference in mean CSI and mean subcomponent scores for EM-headquartered firms. Statistics are for the sample period January 2, 2007 to July 31, 2020.

	Developed Market Difference					Emerging Market Difference				
	CSI	E	S	G	CC	CSI	E	S	G	CC
#Obs	4,600	4,473	4,522	4,332	4,509	2,517	1,878	2,057	2,191	2,339
Minimum	-34.23	-34.19	-29.98	-37.96	-34.99	-53.94	-50.27	-51.94	-48.09	-47.55
Maximum	63.69	61.58	64.44	56.81	63.45	53.30	39.69	37.37	42.10	56.80
Mean	9.31	12.01	12.85	7.77	9.04	-5.47	-6.66	-7.24	-3.99	-4.61
Std. Deviation	10.65	11.22	10.50	10.57	10.28	12.78	11.79	11.59	12.77	12.50

Table 14: Difference in CSI Scores Abroad and at Home as a Function of Difference in Subcomponent Scores, by Market Headquarters

This table reports the OLS coefficient estimates and *t*-statistics for equations 3a and 3b using daily data for the sample period January 2, 2007 to July 31, 2020. Panel A regresses the independent variables (abroad-home difference in subcomponent scores) on the dependent variable *DM_DIFF_CSI*, representing the abroad-home difference in DM-headquartered firm CSI scores. Panel B regresses the independent variables (abroad-home difference in subcomponent scores) on *EM_DIFF_CSI*, representing the abroad-home difference in EM-headquartered firm CSI scores. Figures marked with ***, **, * are significant at the 1%, 5%, and 10% levels, respectively.

Dependent Variable	Panel A	Panel B
	<i>DM_DIFF_CSI</i>	<i>EM_DIFF_CSI</i>
Constant	-1.34	1.11
<i>DM_DIFF_E</i>	0.028*** (3.13)	--
<i>DM_DIFF_S</i>	0.428*** (38.30)	--
<i>DM_DIFF_G</i>	0.110*** (12.83)	--
<i>DM_DIFF_CC</i>	0.441*** (40.26)	--
<i>EM_DIFF_E</i>	--	0.107*** (6.09)
<i>EM_DIFF_S</i>	--	0.179*** (9.13)
<i>EM_DIFF_G</i>	--	0.267*** (17.15)
<i>EM_DIFF_CC</i>	--	0.502*** (29.15)
Joint Test, F	6,165.95	2,255.95
P-value	0.000	0.000
R ²	0.853	0.845
#Obs	4,257	1,658

Table 15: Difference in Coefficients of Subcomponent Scores

This table reports the difference in subcomponent coefficient estimates from the OLS regressions presented in Table 14, with the t -statistics shown in parentheses. Panel A shows results for the difference in DM-headquartered subcomponent *DIFF* scores. Panel B shows results for the difference in EM-headquartered subcomponent *DIFF* scores. Figures marked with ***, **, * are significant at the 1%, 5%, and 10% levels, respectively.

Panel A: Difference in DM Subcomponent <i>DIFF</i> Scores			
	<i>DM_DIFF_E</i>	<i>DM_DIFF_S</i>	<i>DM_DIFF_G</i>
<i>DM_DIFF_S</i>	-0.400*** (22.31)		
<i>DM_DIFF_G</i>	-0.082*** (5.86)	0.318*** (23.86)	
<i>DM_DIFF_CC</i>	-0.413*** (30.25)	-0.013 (0.69)	-0.331*** (19.33)
Panel B: Difference in EM Subcomponent <i>DIFF</i> Scores			
	<i>EM_DIFF_E</i>	<i>EM_DIFF_S</i>	<i>EM_DIFF_G</i>
<i>EM_DIFF_S</i>	-0.072** (2.09)		
<i>EM_DIFF_G</i>	-0.160*** (6.67)	-0.088*** (3.42)	
<i>EM_DIFF_CC</i>	-0.395*** (15.74)	-0.323*** (11.08)	-0.235*** (7.80)

Table 18: Summary Statistics and Tukey's HSD for Mean CSI Scores Over Time by Market Headquarters, at Home and Abroad

Panel A shows DM-headquartered mean CSI scores split by location of incident (at home in DM and abroad in EM) for subsample time periods t_1 - t_4 , while Panel B shows EM-headquartered scores split by location of incident (at home in EM and abroad in DM) for subsample time periods t_1 - t_4 . The last line of the table shows the results for Tukey's HSD for the difference in paired mean scores, $t_x - t_{x-1}$, where t_x represents four equal portions of the sample period January 2, 2007 to July 31, 2020. Figures market with ***, **, * are significant at the 1%, 5%, and 10% levels, respectively.

	Panel A: DM-Headquartered								Panel B: EM-Headquartered							
	DM Home				DM Abroad				EM Home				EM Abroad			
	t1	t2	t3	t4	t1	t2	t3	t4	t1	t2	t3	t4	t1	t2	t3	t4
#Obs	1,093	1,235	1,236	1,239	1,090	1,178	1,203	1,228	959	1,137	1,212	1,233	250	495	845	973
Minimum	20.23	23.95	22.71	28.61	20.23	20.23	17.75	23.06	20.23	19.82	20.23	21.47	20.23	20.23	20.23	20.23
Maximum	77.70	70.85	73.82	85.94	90.34	88.96	95.40	91.57	89.23	80.22	86.47	92.31	70.31	69.97	80.46	86.82
Mean	40.02	44.74	50.02	50.58	50.75	55.01	58.43	58.07	43.77	42.70	48.46	50.72	36.64	36.06	42.73	48.87
Std. Deviation	8.54	6.51	5.86	5.88	13.73	10.20	8.20	8.86	13.09	10.49	9.77	9.93	10.51	9.99	11.98	14.42
Tukey's HSD, $t_x - t_{x-1}$		4.722***	5.279***	0.563		4.263***	3.418***	-0.358		-1.070	5.762***	2.264***		-0.582	6.670***	6.143***

Table 19: Summary Statistics, Tukey's HSD for Mean Subcomponent Scores Over Time by Market Headquarters, at Home and Abroad

The table is divided into four sections for each of the subcomponent scores Environmental, Social, Governance, and Cross-Cutting. Within each section, Panel A shows DM-headquartered scores by location of incident (at home in DM and abroad in EM) for subsamples t_1 - t_4 , while Panel B shows EM-headquartered scores by location of incident (at home in EM and abroad in DM) for subsamples t_1 - t_4 . The last line of the table shows the results for Tukey's HSD for the difference in paired mean scores, $t_x - t_{x-1}$, where t_x represents four equal portions of the sample period January 2, 2007 to July 31, 2020. Figures marked with ***, **, * are significant at the 1%, 5%, and 10% levels, respectively.

Environmental Scores																
	Panel A: DM-Headquartered								Panel B: EM-Headquartered							
	DM Home				DM Abroad				EM Home				EM Abroad			
	t1	t2	t3	t4	t1	t2	t3	t4	t1	t2	t3	t4	t1	t2	t3	t4
#Obs	1,043	1,231	1,235	1,237	1,036	1,156	1,192	1,219	880	1,087	1,182	1,216	187	310	628	801
Minimum	18.63	13.59	19.20	24.62	18.77	17.37	16.17	15.22	13.71	10.68	14.18	15.32	19.24	14.81	12.88	10.30
Maximum	72.41	79.37	61.01	68.25	90.17	91.84	84.00	82.03	84.85	80.50	83.42	88.92	70.31	68.25	78.12	70.27
Mean	38.21	40.30	40.82	42.10	49.20	52.27	53.96	53.17	43.37	43.03	47.10	47.45	35.64	37.42	41.13	43.52
Std. Deviation	8.30	7.29	5.09	5.57	14.28	11.21	8.54	9.45	12.95	10.78	9.34	8.90	9.89	10.58	9.59	9.90
Tukey's HSD, $t_x - t_{x-1}$		2.082***	0.520	1.289***		3.072***	1.688***	-0.791		-0.346	4.069***	0.354		1.782	3.708***	2.387***
Social Scores																
	Panel A: DM-Headquartered								Panel B: EM-Headquartered							
	DM Home				DM Abroad				EM Home				EM Abroad			
	t1	t2	t3	t4	t1	t2	t3	t4	t1	t2	t3	t4	t1	t2	t3	t4
#Obs	1,038	1,232	1,236	1,239	1,064	1,168	1,201	1,226	915	1,105	1,202	1,226	194	364	678	866
Minimum	18.89	16.09	20.64	26.09	16.06	15.05	17.75	20.23	16.47	11.50	17.84	14.00	16.17	14.74	8.06	10.73
Maximum	74.02	69.96	64.48	64.34	89.79	88.76	95.00	82.49	89.11	82.52	84.78	92.17	70.31	68.55	78.23	70.37
Mean	38.96	41.59	43.22	43.83	50.98	54.94	57.25	55.00	44.25	43.50	47.10	46.38	35.73	37.14	39.47	42.87
Std. Deviation	8.27	6.49	5.17	4.52	13.75	10.41	8.48	8.68	13.91	10.91	9.40	8.51	10.53	10.68	9.07	10.16
Tukey's HSD, $t_x - t_{x-1}$		2.63***	1.629***	0.609*		3.967***	2.309***	-2.247***		-0.750	3.595***	-0.719		1.409	2.327***	3.395***
Governance Scores																
	Panel A: DM-Headquartered								Panel B: EM-Headquartered							
	DM Home				DM Abroad				EM Home				EM Abroad			
	t1	t2	t3	t4	t1	t2	t3	t4	t1	t2	t3	t4	t1	t2	t3	t4
#Obs	886	1,228	1,235	1,239	918	1,156	1,197	1,222	653	1,057	1,205	1,226	92	417	797	931
Minimum	11.58	16.92	22.95	24.66	11.45	16.56	20.62	17.49	16.47	10.14	20.05	18.99	19.87	10.14	14.28	11.96
Maximum	68.51	74.11	76.27	86.03	80.06	89.11	95.23	91.42	78.12	77.49	84.52	92.29	59.01	67.25	78.92	87.13
Mean	35.77	40.67	46.47	47.63	44.32	48.44	53.59	55.27	36.30	37.64	44.54	49.35	33.62	33.52	40.79	47.97
Std. Deviation	8.64	6.86	6.54	6.27	12.82	10.56	8.62	9.10	12.49	10.62	10.23	10.83	9.66	9.62	12.14	14.69
Tukey's HSD, $t_x - t_{x-1}$		4.895***	5.801***	1.161***		4.126***	5.145***	1.679***		1.336*	6.903***	4.807***		-0.102	7.265***	7.18***
Cross-Cutting Scores																
	Panel A: DM-Headquartered								Panel B: EM-Headquartered							
	DM Home				DM Abroad				EM Home				EM Abroad			
	t1	t2	t3	t4	t1	t2	t3	t4	t1	t2	t3	t4	t1	t2	t3	t4
#Obs	1,035	1,233	1,236	1,239	1,036	1,171	1,201	1,227	834	1,112	1,205	1,232	191	446	812	938
Minimum	17.08	21.34	20.23	26.19	16.06	18.11	14.27	17.55	14.84	10.68	21.99	15.13	17.08	14.14	10.83	13.67
Maximum	68.34	68.39	75.31	85.99	88.80	84.78	91.34	92.58	85.18	78.78	82.48	90.44	59.41	67.26	78.27	86.69
Mean	37.58	42.35	47.39	47.66	47.15	52.21	55.65	55.76	39.91	39.04	45.45	48.37	35.46	34.19	40.08	46.86
Std. Deviation	7.98	6.08	5.89	5.64	13.31	9.76	8.16	9.08	12.45	9.87	9.73	9.99	9.80	9.43	11.15	14.04
Tukey's HSD, $t_x - t_{x-1}$		4.766***	5.044***	0.269		5.06***	3.441***	0.109		-0.873	6.407***	2.92***		-1.271	5.886***	6.779***

Table 20: Histogram of DM-headquartered CSI scores, at home and abroad, over time

Panel A shows the distribution of DM CSI scores at home, Panel B shows the distribution of DM CSI scores abroad. The top charts are for the full sample, followed by subsamples for time periods t_1 - t_4 , which represent equal portions of the sample period January 2, 2007 to July 31, 2020.

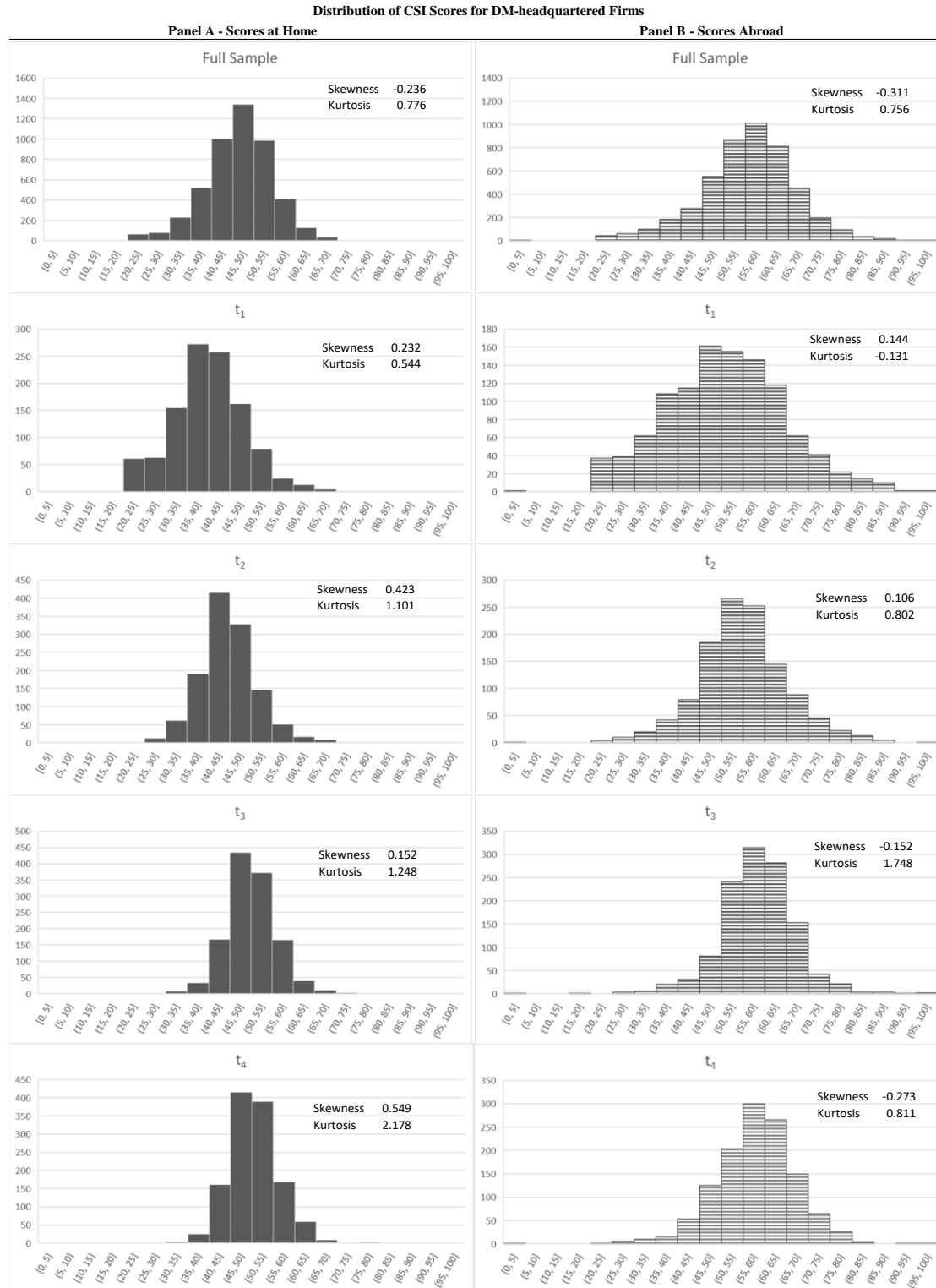

Table 21: Histogram of EM-headquartered CSI scores, at home and abroad, over time

Panel A shows EM CSI scores at home, Panel B shows EM CSI scores abroad. The top chart is for the full sample, followed by subsamples for time periods t_1 - t_4 , which represent equal portions of the sample period January 2, 2007 to July 31, 2020.

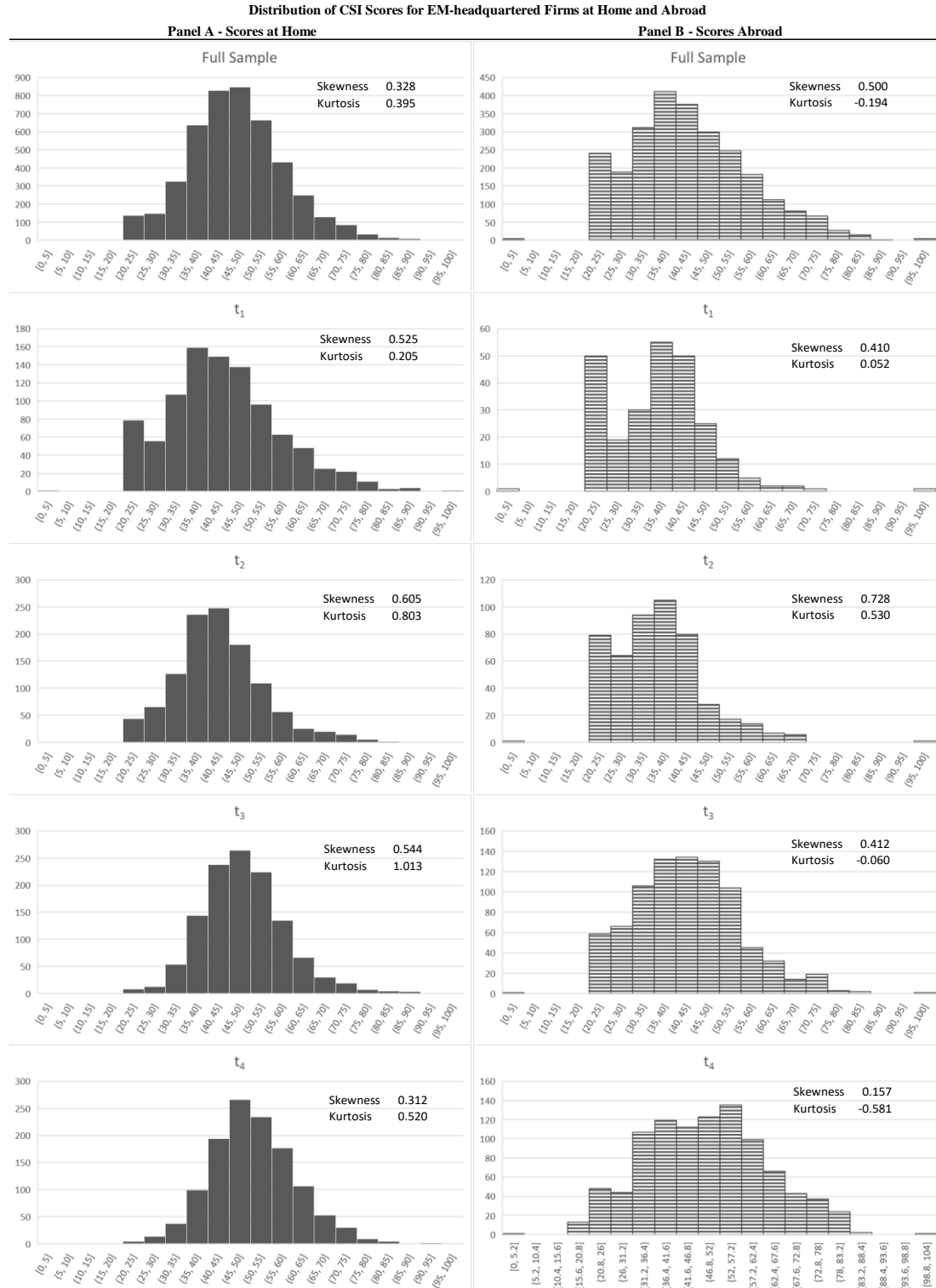

Table 22: Top Incident Counts by Country

Panel A is the number CSI incidents by country of headquarters as a percent of total CSI incidents, while Panel B is the number of CSI incidents by country where the incident occurred as a percent of total CSI incidents. Data is daily for the sample period January 2, 2007 to July 31, 2020.

Top CSI Incident Counts by Country as Percent of Global Incidents

Panel A		Panel B	
By Headquarters (Perpetrator)		By Incident Location	
United States of America	33%	United States of America	15%
United Kingdom	7%	China	5%
Korea	6%	Brazil	3%
China	5%	United Kingdom	3%
Germany	5%	Korea	3%
Japan	4%	India	3%
Canada	4%	Indonesia	2%
France	4%	Canada	2%
Switzerland	4%	Russian Federation	2%
Brazil	4%	Germany	2%

REFERENCES

- Amor-Esteban, V., Galindo-Villardón, M.-P., & David, F. (2018). Study of the Importance of National Identity in the Development of Corporate Social Responsibility Practices: A Multivariate Vision [Article]. *Administrative Sciences (2076-3387)*, 8(3), 50. <https://doi.org/10.3390/admsci8030050>
- Cai, Y., Pan, C. H., & Statman, M. (2016). Why do countries matter so much in corporate social performance? [Article]. *Journal of Corporate Finance*, 41, 591-609. <https://doi.org/10.1016/j.jcorpfin.2016.09.004>
- Capelle-Blancard, G., & Petit, A. (2019). Every Little Helps? ESG News and Stock Market Reaction [Article]. *Journal of Business Ethics*, 157(2), 543-565. <https://doi.org/10.1007/s10551-017-3667-3>
- Chatterji, A. K., Durand, R., Levine, D. I., & Touboul, S. (2016). DO RATINGS OF FIRMS CONVERGE? IMPLICATIONS FOR MANAGERS, INVESTORS AND STRATEGY RESEARCHERS [Article]. *Strategic Management Journal (John Wiley & Sons, Inc.)*, 37(8), 1597-1614. <https://doi.org/10.1002/smj.2407>
- DiMaggio, P. J., & Powell, W. W. (1983). THE IRON CAGE REVISITED: INSTITUTIONAL ISOMORPHISM AND COLLECTIVE RATIONALITY IN ORGANIZATIONAL FIELDS [Article]. *American Sociological Review*, 48(2), 147-160. <https://doi.org/10.2307/2095101>
- Dimson, E., Karakaş, O., & Xi, L. (2015). Active Ownership [Article]. *Review of Financial Studies*, 28(12), 3225-3268. <https://doi.org/10.1093/rfs/hhv044>
- Dimson, Elroy and Karakaş, Oğuzhan and Li, Xi, Coordinated Engagements (November 11, 2020). European Corporate Governance Institute – Finance Working Paper No. 721/2021, Available at SSRN: <https://ssrn.com/abstract=3209072> or <http://dx.doi.org/10.2139/ssrn.3209072>
- Dorflleitner, G., Halbritter, G., & Nguyen, M. (2015). Measuring the level and risk of corporate responsibility - An empirical comparison of different ESG rating approaches. *Journal of Asset Management*, 16(7), 450-466. <https://doi.org/http://dx.doi.org/10.1057/jam.2015.31>

- Dyck, A., Lins, K. V., Roth, L., & Wagner, H. F. (2019). Do institutional investors drive corporate social responsibility? International evidence [Article]. *Journal of Financial Economics*, 131(3), 693-714. <https://doi.org/10.1016/j.jfineco.2018.08.013>
- Dyck, A., Morse, A., & Zingales, L. (2010). Who Blows the Whistle on Corporate Fraud? [Article]. *Journal of Finance (John Wiley & Sons, Inc.)*, 65(6), 2213-2253. <https://doi.org/10.1111/j.1540-6261.2010.01614.x>
- Fausser, D. V., & Utz, S. (2021). Risk Mitigation of Corporate Social Performance in US Class Action Lawsuits [Article]. *Financial Analysts Journal*, 77(2), 43-65. <https://doi.org/10.1080/0015198X.2020.1861896>
- Fiaschi, D., Giuliani, E., & Nieri, F. (2017). Overcoming the liability of origin by doing no-harm: Emerging country firms' social irresponsibility as they go global [Article]. *Journal of World Business*, 52(4), 546-563. <https://doi.org/10.1016/j.jwb.2016.09.001>
- Filatotchev, I., Poulsen, A., & Bell, R. G. (2019). Corporate governance of a multinational enterprise: Firm, industry and institutional perspectives [Article]. *Journal of Corporate Finance*, 57, 1-8. <https://doi.org/10.1016/j.jcorpfin.2018.02.004>
- Filatotchev, I., & Stahl, G. K. (2015). Towards transnational CSR: Corporate social responsibility approaches and governance solutions for multinational corporations [Article]. *Organizational Dynamics*, 44(2), 121-129. <https://doi.org/10.1016/j.orgdyn.2015.02.006>
- Gugler, P., & Shi, J. (2009). Corporate Social Responsibility for Developing Country Multinational Corporations: Lost War in Pertaining Global Competitiveness? [Article]. *Journal of Business Ethics*, 87, 3-24. <https://doi.org/10.1007/s10551-008-9801-5>
- Ioannou, I., & Serafeim, G. (2012). What drives corporate social performance? The role of nation-level institutions [Article]. *Journal of International Business Studies*, 43(9), 834-864. <https://doi.org/10.1057/jibs.2012.26>

- Koh, P. S., Qian, C., & Wang, H. (2014). FIRM LITIGATION RISK AND THE INSURANCE VALUE OF CORPORATE SOCIAL PERFORMANCE [Article]. *Strategic Management Journal (John Wiley & Sons, Inc.)*, 35(10), 1464-1482. <https://doi.org/10.1002/smj.2171>
- Krüger, P. (2015). Corporate goodness and shareholder wealth [Article]. *Journal of Financial Economics*, 115(2), 304-329. <https://doi.org/10.1016/j.jfineco.2014.09.008>
- Marano, V., Tashman, P., & Kostova, T. (2017). Escaping the iron cage: Liabilities of origin and CSR reporting of emerging market multinational enterprises [Article]. *Journal of International Business Studies*, 48(3), 386-408. <https://doi.org/10.1057/jibs.2016.17>
- Strike, V. M., Jijun, G., & Bansal, P. (2006). Being good while being bad: social responsibility and the international diversification of US firms [Article]. *Journal of International Business Studies*, 37(6), 850-862. <https://doi.org/10.1057/palgrave.jibs.8400226>
- Surroca, J., Tribó, J. A., & Zahra, S. A. (2013). STAKEHOLDER PRESSURE ON MNEs AND THE TRANSFER OF SOCIALLY IRRESPONSIBLE PRACTICES TO SUBSIDIARIES [Article]. *Academy of Management Journal*, 56(2), 549-572. <https://doi.org/10.5465/amj.2010.0962>
- Tashman, P., Marano, V., & Kostova, T. (2019). Walking the walk or talking the talk? Corporate social responsibility decoupling in emerging market multinationals [Article]. *Journal of International Business Studies*, 50(2), 153-171. <https://doi.org/10.1057/s41267-018-0171-7>
- Wright, M., Filatotchev, I., Hoskisson, R. E., & Peng, M. W. (2005). Strategy Research in Emerging Economies: Challenging the Conventional Wisdom [Article]. *Journal of Management Studies (Wiley-Blackwell)*, 42(1), 1-33. <https://doi.org/10.1111/j.1467-6486.2005.00487.x>
- Zyglidopoulos, S., Williamson, P., & Symeou, P. (2016). The Corporate Social Performance of Developing Country Multinationals. *Business Ethics Quarterly*, 26(3), 379-406. <https://doi.org/http://dx.doi.org/10.1017/beq.2016.41>

VITA

Dr. Julie Salsbery is an accomplished executive leader with 25+ years' experience in the asset management industry. During her career, Julie has held numerous strategic roles spanning trading, fixed income and equity investing, market research, business strategy, and client engagement.

Most recently, Julie was the Director of Business Strategy, Investments at Invesco where she was responsible for restructuring the global equity platform and was a regular strategy contributor on Bloomberg television. Previously Julie was Head of Public Debt, Global & Emerging Market Equities at Invesco where she led the new business strategy for Factor and ESG investing, developed global equity investment capabilities, and managed a team of Client Portfolio Managers. Julie has also worked at Pacific Investment Management Company (PIMCO) as a Global and Emerging Markets Strategist and was a Trader, US Economist, and Sovereign Debt Analyst during her time at T. Rowe Price.

Julie is currently a Faculty Lecturer in the Robinson College of Business at Georgia State University where she teaches the Fundamentals of Analysis and is the Faculty Advisor for the Student Managed Investment Fund and the Finance Society. She was recently awarded a post-doctoral grant by the Fulbright U.S. Student Program to study the European approach to sustainable investing at the University of Antwerp. After completing her Fulbright research grant, Julie plans to reengage with practitioners in the field of asset management while remaining an active advocate for and contributor to higher education.

Julie has a Doctor of Philosophy in Business Administration from the J. Mack Robinson College of Business at Georgia State University, a MA in Applied Economics from Johns Hopkins University, and BA in Economics (Magna Cum Laude, with Honors) from the University of Arizona.